

INTERGOVERNMENTAL DATA QUALITY TASK FORCE

# Uniform Federal Policy For Quality Assurance Project Plans

---

Advanced Geophysical Classification for  
Munitions Response

---

(AGC-QAPP)

Version 1.0, March 2016



INTERGOVERNMENTAL DATA QUALITY TASK FORCE

**Uniform Federal Policy  
For  
Quality Assurance Project Plans**

---

Advanced Geophysical Classification for Munitions  
Response

---

(AGC-QAPP)

**Version 1.0, March 2016**

*Charlotte Bertrand*

*5/6/2016*

---

Charlotte Bertrand  
Acting Director, U.S. Environmental Protection Agency, Federal Facilities Restoration and Reuse Office

Date

*Maureen Sullivan*

*3/23/2016*

---

Maureen Sullivan  
Deputy Assistant Secretary of Defense, (Environment, Safety, and Occupational Health)

Date

## Acknowledgement

The Intergovernmental Data Quality Task Force would like to thank the members of the IDQTF Advanced Geophysical Classification (AGC) Subgroup for their time and efforts preparing this document. Comprised of technical experts and stakeholders representing DoD, the Strategic Environmental Research Demonstration Program (SERDP), the Environmental Security Technology Certification Program (ESTCP), the U.S. Environmental Protection Agency (EPA) Federal Facilities Restoration and Reuse Office (FFRRO), and the states of Colorado and California, the AGC Subgroup includes the following members:

Jordan Adelson, PhD, Director, Navy Laboratory Quality and Accreditation Office, NAVSEA 04XQ

Kevin Coats, Chief – Environmental Sciences Division, USACE/EMCX, Huntsville District

William Corl, PhD, Assistant Director, Navy Laboratory Quality and Accreditation Office, NAVSEA 04XQ

Brian Harre, NAVFAC EXWC

Brian Jordan, FUDS Project Manager, USACE, Albuquerque District

Doug Maddox, P.E., U.S. EPA Federal Facilities Restoration and Reuse Office

Herb Nelson, PhD, Program Manager for Munitions Response, SERDP & ESTCP

Roman Racca, P.G., Statewide Munitions Response Coordinator, California EPA, Department of Toxic Substances Control

Andrew Schwartz, Military Munitions Division, U.S. Army Engineering and Support Center, Huntsville

Jeff Swanson, P.E., Federal Facilities Remediation & Reuse Unit, Colorado Department of Public Health & Environment

Amy Walker, Geophysicist, U.S. Army Engineering and Support Center, Huntsville

Carla Garbarini, Principal, NSTECH (Contract support)

Alison Felix, Quality Chemist, BMT Designers & Planners, Inc. (Contract support)

The IDQTF wishes to thank Ms. Deborah Morefield (DoD Co-chair), Mr. Doug Maddox (EPA Co-chair), Steve Cobb (State Co-chair) the members of the Munitions Response Dialog for providing a national forum for stakeholder discussion that has helped promote the transition of advanced geophysical classification from demonstration to common use in the field.

The IDQTF gratefully acknowledges the National Association of Ordnance Contractors for their insights and many helpful comments and suggestions during the development of this document.

## Table of Contents

Preface .....	1
Table1. Crosswalk: Optimized UFP-QAPP Worksheets to GCMR-QAPP Template.....	3
Glossary.....	5
Part 1 – Abbreviations and Acronyms.....	5
Part 2 – Definitions .....	8
QAPP Worksheet #1 & 2: Title and Approval Page.....	13
QAPP Worksheet #3 & 5: Project Organization and QAPP Distribution .....	15
Figure 3-1: Advanced Geophysical Classification Organizational Structure .....	16
Figure 3-2: Explosives Safety Operations Organizational Structure .....	17
QAPP Worksheet #4, 7 & 8: Personnel Qualifications and Sign-off Sheet.....	18
Table 4-1: Advanced Geophysical Classification Organization .....	18
Table 4-2: Explosive Operations Organization.....	21
QAPP Worksheet #6: Communication Pathways and Procedures .....	23
Table 6-1: Communication Pathways and Procedures .....	23
QAPP Worksheet #9: Project Planning Session Summary .....	25
QAPP Worksheet #10: Conceptual Site Model.....	26
QAPP Worksheet #11: Data Quality Objectives.....	27
Table 11-1: Target Population .....	29
QAPP Worksheet #12: Measurement Performance Criteria .....	33
Table 12-1: Measurement Performance Criteria.....	33
QAPP Worksheet #13: Secondary Data Uses and Limitations .....	36
Table 13-1: Secondary Data Uses and Limitations.....	36
QAPP Worksheet #14/16: Project Tasks & Schedule.....	37
Table 14-1: Project Tasks and Schedule.....	37
QAPP Worksheet #17: Survey Design and Project Work Flow .....	40
Figure 17-1: Advanced Geophysical Classification Decision Tree .....	45
QAPP Worksheet #22: Equipment Testing, Inspection, and Quality Control .....	48
Table 22-1: Detection Survey.....	48

Table 22-2: Cued Survey .....	54
Table 22-3: Intrusive Investigation .....	59
QAPP Worksheet #29: Data Management, Project Documents, and Records .....	60
Table 29-1: Minimum Required Documents and Records.....	60
QAPP Worksheet #31, 32 & 33: Assessments and Corrective Action.....	63
Table 31-1: Assessment Schedule.....	64
Table 31-2: Assessment Response and Corrective Action.....	65
QAPP Worksheet #34: Data Verification, Validation, and Usability Inputs .....	66
Table 34-1 Data Verification, Validation and Usability Inputs.....	66
QAPP Worksheet #35: Data Verification and Validation Procedures .....	69
Table 35-1: Data Verification and Validation Procedures.....	69
QAPP Worksheet #36: Advanced Geophysical Classification Validation .....	70
QAPP Worksheet #37: Data Usability Assessment (DUA).....	71
Appendix A: Example Standard Operating Procedures .....	73

## Preface

The Intergovernmental Data Quality Task Force (IDQTF) has produced this Advanced Geophysical Classification Quality Assurance Project Plan (AGC-QAPP) template, as a voluntary consensus document, to assist project teams in planning for the investigation of buried munitions and explosives of concern (MEC) at Department of Defense (DoD) installations and formerly used defense sites (FUDS). The template documents the systematic planning process (SPP) steps leading to *in-situ* detection and classification of MEC and other debris using advanced geophysical classification. This template was developed following extensive research and development of advanced geophysical classification technology under the Environmental Security Technology Certification Program (ESTCP) and the Strategic Environmental Research and Development Program (SERDP). It is based on requirements and guidance contained in the *Uniform Federal Policy for Quality Assurance Project Plans (UFP-QAPP)*, (IDQTF, 2005). It also draws upon similar efforts by the Interstate Technology & Regulatory Council (ITRC) Geophysical Classification for Munitions Response Team. Use of this template will help project teams generate a complete QAPP, i.e., a stand-alone document addressing all elements of the national consensus standard ANSI/ASQ E4-2004, *Quality Systems for Environmental Data and Environmental Technology Programs*. Similar to the overarching policy document *Uniform Federal Policy for Quality Assurance Project Plans (UFP-QAPP)* (IDQTF, 2005), this document was not developed or promulgated through the Federal rulemaking process, it does not have the force of regulation, and is not subject to regulatory enforcement or a Notice of Violation. [Notice of Violations would be applicable only in circumstances in which two parties have chosen to make the use of the AGC-QAPP part of an enforceable agreement.] Once adopted by an agency for a specific program or project, however, use of this document is required to ensure a consistent approach to QAPP development and compliance with ANSI/ASQ E4-2004.

DoD has used military munitions for live-fire testing and training to prepare the United States military for combat operations. As a result, MEC, including unexploded ordnance (UXO) and discarded military munitions (DMM) may be present on former ranges and other facilities (such as production and disposal areas). During a traditional cleanup, a site is typically mapped using either a magnetometer or electromagnetic induction (EMI) sensor, and the locations of all signals above a stated detection threshold are excavated, because this technology does not provide a validated means to discriminate between MEC and nonhazardous metallic debris. Experience has shown that most of the costs to remediate munitions-contaminated sites have been spent excavating items that pose no threat. Remediation of the entire inventory of munitions-contaminated sites in this manner would be cost-prohibitive, and estimated completion dates for munitions response at many sites would be decades away.

Advanced geophysical classification uses advanced geophysical sensors and classifiers to estimate physical properties of the item (e.g., depth, size, aspect ratio, wall thickness, symmetry) and determine whether the item is a target of interest (TOI) (i.e., highly likely to be MEC) or non-TOI (i.e., highly unlikely to be MEC). Using this information in a structured decision-making process, documented in a project-

specific QAPP, project teams will be able to make informed decisions about whether an item should be excavated or can be left in place. Following more than a decade of research and development, the technology has been successfully demonstrated on several live sites under the ESTCP, even as it continues to evolve. Use of this technology has the potential for significant cost savings by avoiding unnecessary and costly excavation of non-hazardous debris, and thus expediting the cleanup and reuse of munitions response sites.

The AGC-QAPP template follows the format of the Optimized UFP-QAPP Worksheets (IDQTF, 2012); however, use of the original UFP-QAPP Workbook (IDQTF, 2005) is also acceptable. This template provides information and examples to facilitate the SPP and not replace it. Use of the template will result in a more rigorous, transparent, and better documented investigation. It should be noted there are some distinct differences between the SPP used for AGC and that used for typical environmental (i.e., chemical) investigations:

1. Unlike traditional chemical investigations where a sample of the soil is taken from the field and sent to an off-site laboratory for analysis, geophysical data for target identification and classification are collected *in-situ*. Data processing may take place either in the field or off-site.
2. The AGC process is performed dynamically, allowing decision-making to occur while project teams are in the field; therefore, a structured process for evaluating data quality and subsequently making decisions is vital to the success of meeting project objectives.

Because of these differences, the AGC-QAPP does not require all of the worksheets contained in either the original Workbook or the Optimized Worksheets. Table 1 identifies worksheets not used in the template and explains why they have been excluded.

The worksheets in this template include **green text, which provides instructions and guidance on completing each worksheet**. Certain worksheets also include **blue text, which provides examples of the types of information typically needed**. Green and blue text should be removed before completing a project-specific QAPP. Where applicable, minimum recommended requirements are presented in black text. Guidance, examples, and minimum recommended requirements contained in this template are based on the Remedial Action (RA) phase of investigation; therefore, they will not apply to every situation. Project teams should modify this template as needed to suit other phases of investigation and their project-specific data quality objectives (DQOs). The rationale for any changes to black text must be specifically identified, documented and concurred upon by the project team. A convenient and efficient way to do this is to provide an appendix to the project-specific QAPP describing any changes and providing the rationale.

The following limitations should be noted:

- This template addresses detection and classification only. It does not address the intrusive investigation (removal of items) or associated explosives safety operations per se.

- Although modern advanced geophysical classification technologies have dramatically increased the accuracy and sensitivity of geophysical investigations, it cannot be assumed that 100% of all MEC can be identified and removed at all sites.
- Advanced geophysical classification does not evaluate potential risks from munitions constituents (MC).
- Wherever possible, a global positioning system (GPS) with centimeter-level precision, or other high-precision positioning system, should be used for referencing sample locations. The examples in this template cannot be used for line and fiducial positioning.
- Advanced geophysical classification may not be suitable for use at all sites. Readers should refer to the ITRC document, “Geophysical Classification for Munitions Response”, August 2015 for further guidance on its uses and limitations.
- Users of this AGC-QAPP template must comply with any applicable State, Federal, and DoD Component-specific requirements, policies, and procedures.

**Table 1. Crosswalk: Optimized UFP-QAPP Worksheets to GCMR-QAPP Template**

Optimized UFP-QAPP Worksheets		GCMR-QAPP Template
1 & 2	Title and Approval Page	Included
3 & 5	Project Organization and QAPP Distribution	Included
4 , 7 & 8	Personnel Qualifications and Sign-off Sheet	Included
6	Communication Pathways and Procedures	Included
9	Project Planning Session Summary	Included
10	Conceptual Site Model	Included
11	Project/Data Quality Objectives	Included
12	Measurement Performance Criteria	Included
13	Secondary Data Uses and Limitations	Included
14 & 16	Project Tasks & Schedule	Included
15	Project Action Limits and Laboratory-Specific Detection /Quantitation Limits	Not applicable – no chemical testing being performed
17	Sampling Design and Rationale	Included – Title changed to “Survey Design and Project Work Flow”



**Table 1. Crosswalk: Optimized UFP-QAPP Worksheets to GCMR-QAPP Template**

Optimized UFP-QAPP Worksheets		GCMR-QAPP Template
18	Sampling Locations and Methods	Not applicable – No environmental samples being collected
19 & 30	Sample Containers, Preservation, and Hold Times	Not applicable – No environmental samples being collected
20	Field Quality Control (QC)	Worksheet not included. Field QC procedures are included on Worksheet #22
21	Field Standard Operating Procedures (SOPs)	Worksheet not included. SOPs are referenced on Worksheet #22
22	Field Equipment Calibration, Maintenance, Testing, and Inspection	Included – Title changed to “Equipment Testing, Inspection, and Quality Control
23	Analytical SOPs	Not applicable – no laboratory analysis being performed
24	Analytical Instrument Calibration	Not applicable – no laboratory analysis being performed
25	Analytical Instrument and Equipment Maintenance, Testing, and Inspection	Not applicable – no laboratory analysis being performed
26 & 27	Sample Handling, Custody, and Disposal	Not applicable – no samples being collected
28	Analytical Quality Control and Corrective Action	Not applicable – no laboratory analysis being performed
29	Project Documents and Records	Included –title changed to “Data Management, Project Documents and Records”
31, 32 & 33	Assessments and Corrective Action	Included
34	Data Verification and Validation Inputs	Included – title changed to “Data Verification, Validation, and Usability Inputs”
35	Data Verification Procedures	Included – title changed to “Data Verification and Validation Procedures”
36	Data Validation Procedures	Included – title changed to “Advanced Geophysical Classification Validation”
37	Data Usability Assessment	Included

## **Glossary**

### **Part 1 – Abbreviations and Acronyms**

**(A) Ampere**

**(A/E/C) Architecture, Engineering, and Construction**

**(AGC-QAPP) Advanced Geophysical Classification Quality Assurance Project Plan**

**(bgs) Below Ground Surface**

**(CA) Corrective Action**

**(CAR) Corrective Action Request**

**(CSM) Conceptual Site Model**

**(DDESB) Department of Defense Explosives Safety Board**

**(DFW) Definable Feature of Work**

**(DGM) Digital Geophysical Mapping**

**(DMM) Discarded Military Munitions**

**(DoD) Department of Defense**

**(DQI) Data Quality Indicator**

**(DQO) Data Quality Objective**

**(DUA) Data Usability Assessment**

**(EMI) Electromagnetic Induction**

**(EPA) U.S. Environmental Protection Agency**

**(ESRI) Environmental System Research Institute**

**(ESTCP) Environmental Security Technology Certification Program**

**(FUDES) Formerly Used Defense Sites**

**(GIS) Geographic Information System**

**(GPS) Global Positioning System**

**(HAZWOPER) Hazardous Waste Operations and Emergency Response**

**(IDQTF) Intergovernmental Data Quality Task Force**

**(IMU) Inertial Measurement Unit**

**(ISO) Industry Standard Object**

**(ISO 80) Schedule 80 small Industry Standard Object**

**(ISO/IEC) International Organization for Standardization/International Electrotechnical Commission**

**(ITRC) Interstate Technology Regulatory Council**

**(IVS) Instrument Verification Strip**

**(MC) Munitions Constituents**

**(MEC) Munitions and Explosives of Concern**

**(MPC) Measurement Performance Criteria**

**(MQO) Measurement Quality Objective**

**(PA) Preliminary Assessment**

**(pdf) portable document format**

**(PM) Project Manager**

**(QA) Quality Assurance**

**(QC) Quality Control**

**(QAPP) Quality Assurance Project Plan**

**(RA) Remedial Action**

**(RCA) Root Cause Analysis**

**(RI/FS) Remedial Investigation/Feasibility Study**

**(RPM) Remedial Project Manager**

**(SDSFIE) Spatial Data Standards for Facilities, Infrastructure, and Environment**

**(SI) Site Inspection**

**(SNR) Signal to noise ratio**

**(SOP) Standard operating procedure**

**(SPP) Systematic Planning Process**

**(SUXOS) Senior UXO Supervisor**

**(TBD) to be determined**

**(TPP) Technical Project Planning**

**(TOI) Target of Interest**

**(Tx/Rx) transmit/receive**

**(UFP QAPP) Uniform Federal Policy for Quality Assurance Project Plans**

**(USACE) U.S. Army Corps of Engineers**

**(UXO) Unexploded Ordnance**

**(UXOQCS) Unexploded Ordnance Quality Control Specialist**

**(UXOSO) Unexploded Ordnance Safety Officer**

## Part 2 – Definitions

Accuracy A measure of the overall agreement of a measurement to a known or accepted reference value. Accuracy includes a combination of random error (precision) and systematic error (bias). [EPA]

Advanced geophysical classification The use of data from an advanced geophysical sensor system to estimate the intrinsic properties of a buried metal object; specifically, for munitions response and UXO removal, to determine whether the object is a target of interest (TOI) that must be removed or other non-explosive debris (non-TOI) that can be left in the ground. Intrinsic properties include size, symmetry, aspect ratio, material composition, and wall thickness. Advanced geophysical classification requires three components: 1) a geophysical sensor system capable of measuring EM signals from multiple aspects, 2) a model to estimate intrinsic properties of the buried item based on its polarizability decay curve or “EMI fingerprint”, and 3) classification algorithms to assign likelihood that a buried item is a target of interest. [SERDP, ESTCP]

Anomaly As used in geophysics, a deviation from an expected background condition that can result from either a real, physical change (e.g. buried metal object) in the subsurface, or various kinds of interference related to the geophysical equipment or external sources. Note: The anomaly is the deviation. It is to be differentiated from the buried metal object or “source” resulting in the anomaly.

Background verification Process of verifying that a proposed location for background measurements is, in fact, free of buried metal. The process involves collecting a static measurement at the proposed background location and four more measurements offset by a half sensor width in the four cardinal directions. If the measured amplitudes of all five measurements are within the noise level of each other, then the user can have confidence that the proposed location is free of buried metal.

Classification validation A qualitative assessment of the EMI fingerprints predicted from geophysical inversions used to evaluate overall investigation performance. This is achieved by making one or more predictions about the size or general shape of non-TOI items selected by the project team, followed by excavation of the items and comparison of actual intrinsic characteristics to predicted characteristics. It may also include a comparison of actual to predicted extrinsic properties such as location and depth of the item. [EDQW]

Classifier Software (algorithm) used during advanced classification to assign likelihood, based on the EMI fingerprint of a buried metallic item, that the item is a target of interest. [SERDP, ESTCP]

Comparability A qualitative measure of the confidence with which one data set or method can be compared to another. The ability to describe likenesses and differences in the quality and relevance of two or more data sets. [EPA]

Completeness A measure of the amount of valid data obtained from a measurement system. The quantity of data that is successfully collected with respect to the amount intended in the experimental design. [EPA]

Cued survey Collection of geophysical data by positioning an advanced EMI sensor over each buried metal object and then collecting 60-120 seconds of data. As the technology develops, this step may be combined with the detection step, requiring the collection of fewer cued data and reducing data collection to one mobilization. [ITRC]

Data quality objectives (DQOs) Qualitative and quantitative statements of the overall level of uncertainty that a decision-maker will accept in results or decisions based on environmental data. They provide the statistical framework for planning and managing environmental data operations consistent with user's needs. [EPA]

Data usability assessment For the purposes of this document, an evaluation of the overall quality of a data set making up a delivery unit, to determine whether the data support their intended uses. It is an evaluation of conformance to the MPCs presented in AGC-QAPP Worksheet #12. [EDQW]

Data validation For the purposes of this document, a detailed evaluation of data for compliance to stated requirements, e.g., the contract, SOPs and MQOs contained in AGC-QAPP Worksheet #22. [EDQW]

Data verification For the purposes of this document, a completeness check that all specified activities involved in data collection and processing have been completed and documented and that the necessary records (objective evidence) are available to proceed to data validation. [EDQW]

Delivery unit For the purposes of this document, a portion of the site, consisting of one or more survey units, for which data verification, data validation, and the data usability assessment have been conducted. Contracting documents normally will establish the specifications for delivery units.

Detection survey The initial mapping and identification of buried metal objects at the site, which can be accomplished using either traditional or advanced geophysical sensors (also called reconnaissance survey or dynamic survey). [ITRC]

Electromagnetic induction (EMI) sensor Geophysical sensors that operate by emitting magnetic fields and detecting the response from electric currents generated when these fields interact with metallic objects. They are often referred to as “all-metals locators.” [SERDP, ESTCP]

EMI fingerprint Set of three magnetic polarizabilities that express how an object responds following electromagnetic excitation along each of its three principal axis directions. These intrinsic properties of the object are determined by geophysical inversion of multi-axis EMI sensor data. [SERDP, ESTCP]

Geophysical inversion A process that uses geophysical data and a physics-based model to iteratively estimate intrinsic properties of a buried item. [SERDP, ESTCP]

Industry standard object (ISO) An object, constructed from steel pipe manufactured to ASTM specifications, used as a munitions surrogate for the purpose of quality assurance or quality control. [ESTCP] [Note: DoD uses the following three types of ISO: 1-inch diameter X 4-inch long Schedule 80 pipe nipple (a surrogate for 37mm projectiles), 2-inch diameter X 8-inch long Schedule 40 pipe nipple (a surrogate for 60-mm mortars), and 4-inch diameter X 12-inch long Schedule 40 pipe nipple (a surrogate for 105mm projectiles)].

Informed source selection (ISS) The use of the extra information inherent in the signals, when advanced EMI sensors are used in the detection phase, to select only those buried metal sources that could be caused by a target of interest (TOI) for further consideration. This technique focuses on the buried metal items (sources) that result in the anomaly rather than the anomaly itself. The advanced EMI sensors can be configured to excite the source along multiple axes and sense the induced fields along three axes for much longer times. This provides at least an order of magnitude more information to use for source selection compared to information produced by a traditional sensor. This extra information can be used to 1) discriminate between a TOI and noise spikes caused by environmental interference, 2) lessen the interference caused by site geology, and 2) discriminate TOI from anomalies caused by small, shallow clutter. [ESTCP]

Instrument verification strip (IVS) A constructed series of buried inert munitions or industry standard objects used to verify proper functioning of the geophysical sensor system. [SERDP, ESTCP]

Geophysical inversion (alternate definition based on ESTCP FAQ) The process of generating polarizability decay curves or “EMI fingerprints” from measured geophysical data through a model-matching process. The decay curves reflect the size, symmetry, aspect ratio, material composition, and wall thickness of the object.

Inversion Fitting measured sensor data from an object to an EMI response model to obtain the model parameters including the object’s location and depth, orientation of its principal axes, and its principal axis response functions. [ITRC]

Library matching The process of comparing the derived polarizabilities of a detected buried metal object (i.e., unknown object) with the polarizabilities of a collection of known munitions items in a library. The objective is to classify the unknown object based on the similarity of its polarizabilities to a library entry.

Measurement performance criteria (MPC) Qualitative and quantitative specifications for measurement activities developed during systematic planning to ensure collected data will satisfy the data quality objectives. MPCs are stated in terms of data quality indicators, including accuracy, representativeness, completeness, comparability and sensitivity. [EPA, various]

Polarizabilities Three principal axis responses returned by the inversion process, which relate directly to the physical attributes of the object under investigation. Information inferred from the responses (e.g. size, shape, aspect ratio and wall thickness) is the basis for classification decisions. [ITRC]

Quality control (QC) seed Industry standard object or inert munition buried at a recorded location and depth, used as a process quality control check for munitions response tasks, including detection surveys, cued surveys, and anomaly recovery operations. The identity, location, and depth of the seed item are blind (not known) to all members of the field team. [EDQW]

Quality system (also management system) The means by which an organization ensures the quality of the products or services it provides and includes a variety of management, technical, and administrative elements such as policies and objectives, procedures and practices, organizational authority, responsibilities, and accountability. [EPA QA G-4]

Representativeness The degree to which a sample or measurement is characteristic of the population for which the sample or measurement is being used to make inferences. [EDQW]

Sensitivity The capability of a method to discriminate between measured responses representing different levels of a variable of interest.

Standard method For the purposes of this document, a method for performing advanced geophysical classification that 1) has been successfully performed in an ESTCP demonstration and 2) is capable of meeting the minimum specifications contained in Appendix B of this document. [EDQW]

Survey unit A portion of the site for which geophysical survey data, including quality control (QC) results and results for blind QC seeds and validation seeds, will be collected, verified, validated, and reported as a unit, for evaluation by the project team. Survey units are established by the project team during project planning. The survey unit is not necessarily a geographically contiguous unit, and survey units for the detection phase may or may not be the same as



those for the cued phase. The survey units should be designed such that data reporting occurs at regular (e.g., weekly) intervals as agreed upon during project planning. [EDQW]

Target of interest (TOI) Any item that must be removed from a munitions response site and subsequently examined to determine whether it is hazardous or inert. Common TOI include unexploded ordnance (UXO), other inert munitions that must be excavated to be identified as inert, quality control (QC) and validation seeds, and substantial components of munitions that the site manager selects for removal. [SERDP, ESTCP]

TOI/non-TOI threshold verification A quality assurance (QA) measure involving the excavation of buried items predicted to be non-TOI, to verify correct placement of the threshold dividing the ranked anomaly list into TOI and non-TOI. Threshold verification targets are selected in consecutive order on the ranked anomaly list, beginning with the first target classified as non-TOI below the threshold. [EDQW]

Validation seed Industry standard object or inert munition buried at a recorded location and depth by, or on behalf of, the government, which is used to evaluate overall contractor performance on advanced geophysical classification. The identity, location, and depth of the seed item are blind to the contractor. [EDQW]

**QAPP Worksheet #1 & 2: Title and Approval Page  
(UFP-QAPP Manual Section 2.1)**

This worksheet identifies the principal points of contact for all organizations having a stakeholder interest in the project. Signatories usually include the DoD Remedial Project Manager (RPM) and Quality Assurance (QA) Manager, contractor Project Manager (PM) and QA Manager, and individuals with oversight authority from regulatory agencies. Signatures indicate that officials have reviewed the QAPP, have had an opportunity to provide comments, and concur with its implementation as written. Add signature lines as necessary to reflect additional stakeholders having approval authority (e.g., explosives safety organizations.) If separate concurrence letters are issued, the original correspondence should be maintained with the final, approved QAPP in the project file. It is the lead organization's responsibility to make sure all signatures are in place before work begins.

1. Project Identifying Information
  - a. Site name/project name
  - b. Site location/number
  - c. Lead organization
  - d. Contractor
  - e. Contract number

2. Lead Organization
  - a. DoD RPM

---

(name/title/signature/date)

- b. DoD QA Manager

---

(name/title/signature/date)

3. Contractor
  - a. Contractor PM

---

(name/title/signature/date)

- b. Contractor QA Manager

---

(name/title/signature/date)

4. Federal Regulatory Agency

---

(name/title/signature/date)

5. State Regulatory Agency

---

(name/title/signature/date)

6. Other Stakeholders (as needed)

---

(name/title/signature/date)

7. List plans and reports from previous investigations relevant to this project

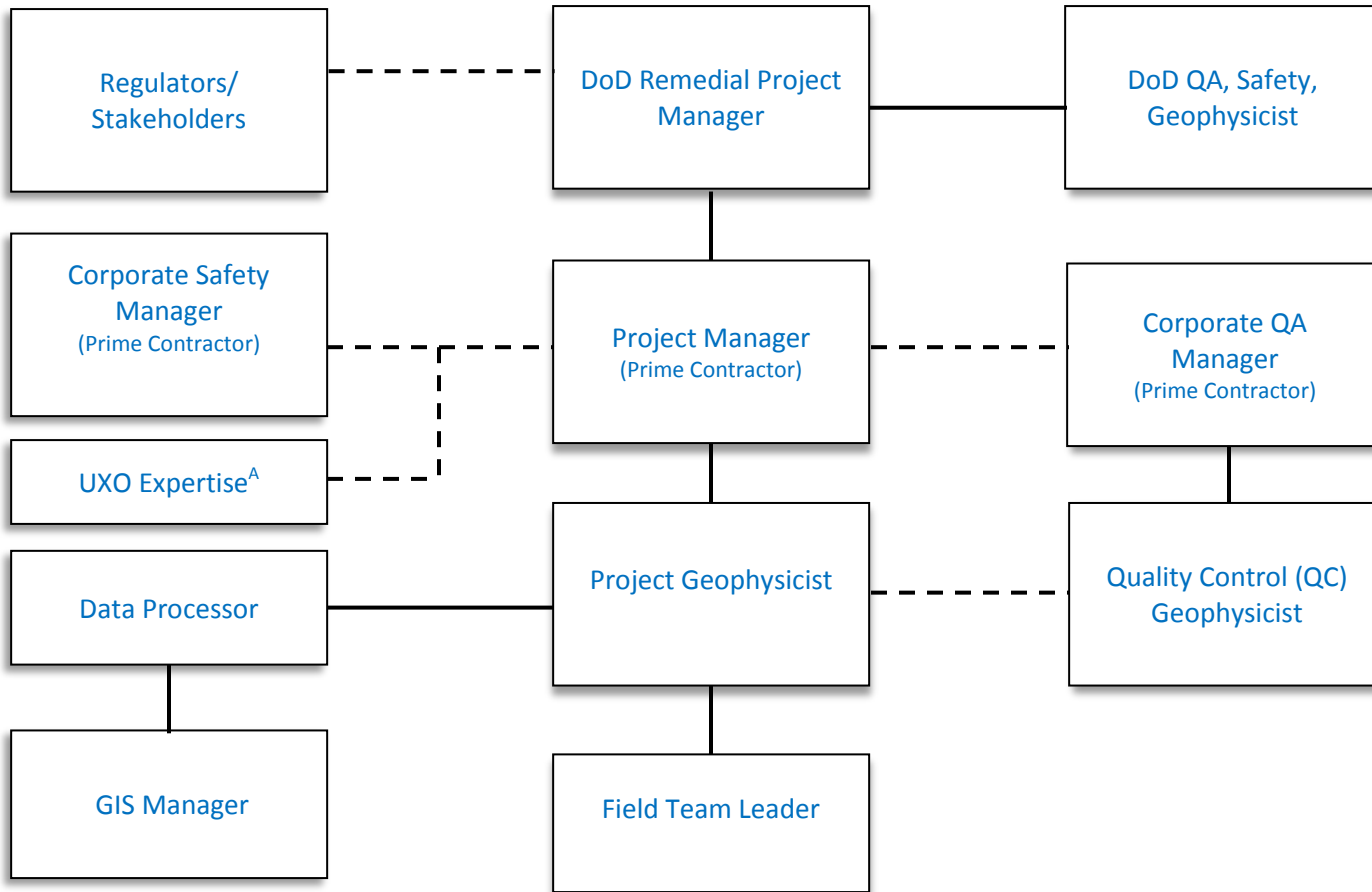
**QAPP Worksheet #3 & 5: Project Organization and QAPP Distribution  
(UFP-QAPP Manual Section 2.3 and 2.4)**

This worksheet identifies key project personnel, as well as lines of authority and lines of communication among the lead organization, prime contractor, subcontractors, and regulatory agencies. Two examples follow. Figure 3-1 provides an example of the structure for the organization performing advanced geophysical classification, and Figure 3-2 provides an example of the structure for the Explosives Safety Operations organization. [Note: Although this template does not address explosives safety per se, including a copy of the organizational structure for the Explosives Safety Operations organization is useful for facilitating project communications.] For the purpose of the draft QAPP, it is permissible to show “to be determined” (TBD) in cases where roles have not been assigned; however, the final, approved QAPP must identify all key personnel. If the Explosives Safety Operations organization is addressed in a separate submittal, that document may be referenced.

For the purpose of document control, this worksheet also can be used to document recipients of controlled copies of the QAPP. The draft QAPP, final QAPP, and any changes/revisions must be provided to all QAPP recipients shown on this chart. Use asterisks or other symbols to designate QAPP recipients. [Alternatively, a list of QAPP recipients along with their contact information may be attached.] Contractors and subcontractors shown on this chart are responsible for document control within their organizations.

Lines of Authority ————— Lines of Communication - - - - -

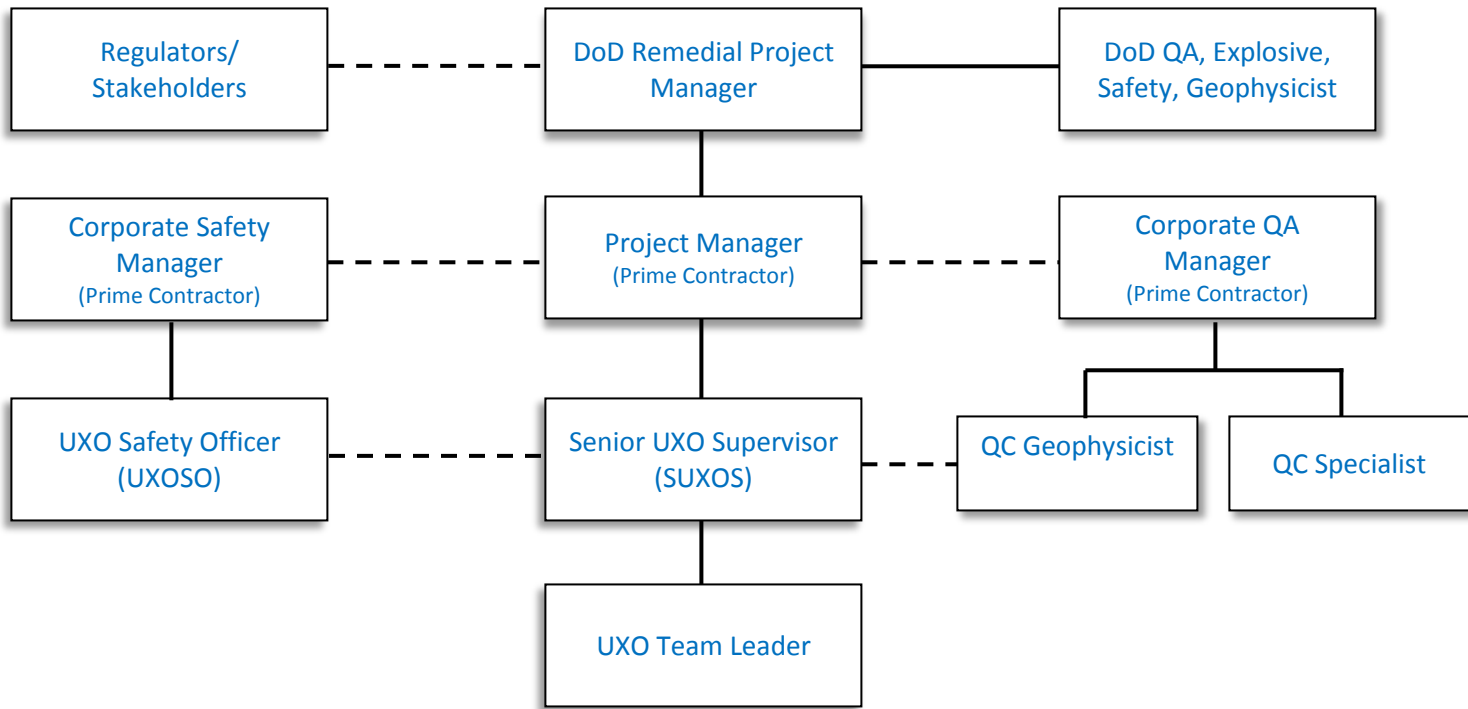
**Figure 3-1: Advanced Geophysical Classification Organizational Structure**



<sup>A</sup> UXO expertise is required to make sure the TOI, which can range from intact munitions to sub-components or fragments with residual explosive and/or chemical constituents, are defined.

Lines of Authority ————— Lines of Communication - - - - -

**Figure 3-2: Explosives Safety Operations Organizational Structure**



**QAPP Worksheet #4, 7 & 8: Personnel Qualifications and Sign-off Sheet**  
**(UFP-QAPP Manual Section 2.3.2 – 2.3.4)**

This worksheet identifies key project personnel for each organization performing tasks defined in this QAPP and summarizes their title or role, qualifications (e.g. training and experience), and any specialized training, licenses, certifications, or clearances required by the project. With the appropriate qualifications, personnel may fill more than one role. Examples are provided in blue text. It is outside the scope of this document to establish minimum qualifications for personnel. Users of this template should add spaces for additional organizations and personnel as needed. Resumes or documentation of relevant experience and training should be contained in an appendix to the QAPP. Signatures indicate personnel have read the QAPP and agree to implement it as written.

**Table 4-1: Advanced Geophysical Classification Organization**

Name/ Contact Information	Project Title/Role	Education/Experience <sup>1</sup>	Specialized Training	Required Licenses/Certifications <sup>2</sup>	Signature/Date
	Project Manager	M.S. Chemistry __ years Managing munitions response projects PM for __ advanced geophysical classification projects			
	Corporate QA Manager	B.S. Civil Engineering Corporate Quality Control (QC) manager for __ years Oversight of __ munitions response projects			

<sup>1</sup> Resumes should be included in an appendix.

<sup>2</sup> This column should include any State-specific requirements.

**Table 4-1: Advanced Geophysical Classification Organization**

Name/ Contact Information	Project Title/Role	Education/Experience <sup>1</sup>	Specialized Training	Required Licenses/Certifications <sup>2</sup>	Signature/Date
	Corporate Safety Manager	M.S. Industrial Engineering		Certified Industrial Hygienist	
	Project Geophysicist	M.S. Physics Project Geophysicist on ESTCP Geophysical Classification demonstration at __	Oasis Montaj Geophysical Data Processing for UXO 3-day UX- Analyze instruction by ESTCP		
	QC Geophysicist	M.S. Physics Project Geophysicist on ESTCP Geophysical Classification demonstration at __	Oasis Montaj Geophysical Data Processing for UXO 3-day UX- Analyze instruction by ESTCP		
	Field Team Leader	B.S. Engineering Field Geophysicist on ESTCP Geophysical Classification demonstration at __	Oasis Montaj Geophysical Data Processing for UXO Working with UX-Analyze		



**Table 4-1: Advanced Geophysical Classification Organization**

Name/ Contact Information	Project Title/Role	Education/Experience <sup>1</sup>	Specialized Training	Required Licenses/Certifications <sup>2</sup>	Signature/Date
	Data Processor	B.S. Physics Project Geophysicist on ESTCP Geophysical Classification demonstration at __	Oasis Montaj Geophysical Data Processing for UXO 3-day UX-Analyze instruction by ESTCP		
	Geographic Information System (GIS) Manager	M.S. in Geoinformatics and Geospatial Intelligence			

**Table 4-2: Explosive Operations Organization**

Name/ Contact Information	Project title/Role	Education/Experience <sup>3</sup>	Specialized Training	Required Licenses/Certifications <sup>4</sup>	Signature/Date
	Project Manager	M.S. Geology __ years managing munitions response projects PM for __ advanced geophysical classification projects	Project Management Professional		
	Corporate QC Manager	B.S. Civil Engineering Corporate QC manager for __ Years Oversight of __ munitions response projects			
	Corporate Safety Manager	M.S. Industrial Engineering		Certified Industrial Hygienist	
	Senior UXO Supervisor (SUXOS)	Graduate Naval EOD School Qualified Senior UXO Supervisor i/a/w Department of Defense Explosives Safety Board (DDESB) TP-18	Emergency Response (HAZWOPER)		

<sup>3</sup> Resumes should be included in an appendix

<sup>4</sup> This column should include any State-specific requirements

**Table 4-2: Explosive Operations Organization**

Name/ Contact Information	Project title/Role	Education/Experience <sup>3</sup>	Specialized Training	Required Licenses/Certifications <sup>4</sup>	Signature/Date
	Unexploded Ordnance QC Specialist (UXOQCS)	B.S. Civil Engineering Qualified UXOQCS i/a/w DDESB TP-18	HAZWOPER		
	QC Geophysicist	M.S. Physics Project Geophysicist on ESTCP Geophysical Classification demonstration at __	Oasis Montaj Geophysical Data Processing for UXO 3-day UX- Analyze instruction by ESTCP		
	UXO Safety Officer	B.S. Civil Engineering Qualified Unexploded Ordnance Safety Officer (UXOSO) i/a/w DDESB TP- 18	HAZWOPER		
	UXO Team Leader	Qualified UXO III i/a/w DDESB TP-18	HAZWOPER		

**QAPP Worksheet #6: Communication Pathways and Procedures  
 (UFP-QAPP Manual Section 2.4.2)**

This worksheet documents specific issues (communication drivers) that will trigger the need for formal (documented) communication with other project personnel or stakeholders. Its purpose is to ensure there are procedures in place for providing notifications, obtaining approvals, and generating the appropriate documentation when handling important communications, including those involving regulatory interfaces, approvals to proceed from one Definable Feature of Work (DFW) to the next, field changes, emergencies, non-conformances, and stop-work orders. Communication pathways and procedures should be agreed upon by the project team during project planning. Examples are provided below; additional communication drivers and procedures should be added as needed.

**Table 6-1: Communication Pathways and Procedures**

<b>Communication Driver</b>	<b>Initiator (name, project title)</b>	<b>Recipient (name, project title)</b>	<b>Procedure (timing, pathway, documentation)</b>
Regulatory agency interface	Name, DoD RPM	Name, Regulatory Organization	DoD RPM provides weekly project update memorandum to Regulator via email
Stop work due to safety issues	Name, Contractor SUXOS	Name, Contractor PM	As soon as possible following discovery, the SUXOS informs Contractor PM by phone of critical safety issues and generates follow-up Stop Work Memorandum
Minor QAPP changes during project execution <sup>5</sup>	Name, QC Geophysicist	Name, Corporate QC Manager and Name, Project Geophysicist	Minor QAPP changes will be noted on the Daily QC reports and forwarded to the Project Geophysicist and the Corporate QC Manager at the end of each day

<sup>5</sup> Project teams should determine what constitutes minor and major QAPP changes during project planning.

**Table 6-1: Communication Pathways and Procedures**

Communication Driver	Initiator (name, project title)	Recipient (name, project title)	Procedure (timing, pathway, documentation)
Major QAPP changes during project execution	Name, Contractor PM	Name, DoD RPM Name, Contractor QA manager	Within 24 hours, Contractor PM submits field change request form to Corporate QA Manager and DoD RPM for approval. Following approval, DoD RPM informs regulator via email.
Mobilization and surface clearance activities are complete	Name, Contractor SUXOS	Name, Contractor PM	Upon completion of surface clearance activities, the SUXOS informs the Contractor PM via Surface Clearance Memorandum.
Daily and weekly QC reports	Name, Contractor PM	Name, DoD RPM	At end of each day/week of field work, Contractor PM provides daily/weekly QC reports to the DoD RPM via email
Geophysical QC variances	Name, Contractor QC Geophysicist	Name, Project Geophysicist and Name, Corporate QC Manager	QC Geophysicist generates Corrective Action Request (CAR) form and transmits to Project Geophysicist and Corporate QC Manager. Project Geophysicist notifies PM by email.

**QAPP Worksheet #9: Project Planning Session Summary  
 (UFP-QAPP Manual Section 2.5.1)**

The GCMR-QAPP worksheets will be completed in a series of project planning sessions, and a copy of this worksheet should be completed for each session, whether the session involves internal project teams (contractor and lead organization only) or includes regulators and other stakeholders. It is used to provide a concise record of participants, key decisions or agreements reached, and action items. Multiple planning sessions typically are required to complete the QAPP, and sessions should involve key technical personnel and decision-makers needed for that specific stage of planning and documentation. If a planning session occurs after the QAPP has been finalized, and the session results in a change to the QAPP, the QAPP and this worksheet should be amended accordingly.

Regardless of planning session format (e.g., phone conference, web-conferencing, or face-to-face meeting), all project planning sessions should be documented. Meeting minutes can be included as attachments if necessary, or referenced. Project teams will find it helpful to have a copy of the entire draft AGC-QAPP template on hand for all planning sessions, in whatever state of completion it may be. The following table may be modified to suit project-specific documentation requirements.

Date of planning session:

Location:

Purpose:

Participants:

Name	Organization	Title/Role	Email/Phone

Notes/Comments:

Consensus decisions made:

Action Items:

Action	Responsible Party	Due Date

### **QAPP Worksheet #10: Conceptual Site Model (UFP-QAPP Manual Section 2.5.2)**

This worksheet presents a concise summary of the project's conceptual site model (CSM) as it relates to the proposed investigation. The CSM is a working, iterative model of site conditions used to assist in the visualization and communication of available information and development of DQOs. The CSM may include text, figures, and tables to depict the current understanding of site conditions. [Note: In August 2015, the ITRC published its guidance document, "Geophysical Classification for Munitions Response" which provides additional information users should find helpful in the development of the CSM.]

At a minimum, the CSM for the RA phase of investigation should include the following information:

- Site history and uses;
- Description of any known or suspected soil movement (e.g., scraping, filling, digging) or possible future soil movement that may be required in association with the site's reuse.
- Types and quantities of MEC known or suspected to be present;
- Expected distribution of MEC present (area, expected maximum depth, depth distribution, anomaly density, etc.);
- Any geophysical data collected to date and interpretations of the data;
- The basis for dividing the site into survey units and delivery units<sup>6</sup>
- Hydrology;
- Topography, geology, vegetation;
- Land use considerations;
- Detailed information on reasonably anticipated future uses;
- Current and future receptors;
- Exposure pathways;
- Access restrictions or other obstacles to investigation;
- Endangered species, sensitive habitats, and historic or cultural resources that could be affected by traffic or other disturbances occurring during the advanced geophysical classification process; and
- Data gaps and uncertainties associated with any information.

---

<sup>6</sup> A survey unit is a portion of the site for which geophysical survey data, including QC results and results for blind QC seeds and validation seeds, will be collected, verified, validated, and reported as a unit, for evaluation by the project team. (It is analogous to an analytical batch in chemical testing). The survey unit is not necessarily a geographically contiguous unit, and survey units for the detection phase may or may not be the same as those for the cued phase. The survey units should be designed such that data reporting and evaluation occurs at regular intervals as agreed upon during project planning.

A delivery unit is a portion of the site, consisting of one or more survey units, for which data verification, data validation, and the data usability assessment have been conducted. Contracting documents normally will establish the specifications for delivery units.

## QAPP Worksheet #11: Data Quality Objectives (UFP-QAPP Manual Section 2.6.1)

This worksheet is used to document DQOs, which are developed during project planning sessions using an SPP. Examples of SPP include: 1) the DQO Process<sup>7</sup>, and 2) the U.S. Army Corps of Engineers' Technical Project Planning (TPP)<sup>8</sup> process. A well-developed, up-to-date CSM is essential to the development of appropriate DQOs. Regardless of the type of SPP applied, the QAPP must document the environmental decisions that need to be made, the type and quantity of data, and level of data quality needed to ensure decisions are based on sound scientific data. The following guidelines are based on EPA's 7-step DQO process. The example is based on the RA phase. DQOs can be presented in tabular format.

**Step 1: State the Problem.** Define the problem that necessitates the study. Examine budget and schedule issues.

Site-specific problem statement: (Example) Previous investigations (list) have indicated that MEC in the form of DMM and UXO including (x, y, and z) are present at site \_\_\_\_\_, resulting from its use between (years) \_\_\_\_\_ and \_\_\_\_\_ as a (describe the type of facility and its uses). As shown in the CSM these materials present an unacceptable risk from explosive hazards to (describe current receptors and potential future receptors based on anticipated land use.)

Advanced geophysical classification uses advanced sensors and geophysical classifiers to estimate physical properties of the item (e.g., depth, size, aspect ratio, wall thickness, symmetry) and determine whether the item is a TOI (i.e., highly likely to be MEC) or non-TOI (i.e., highly unlikely to be MEC). Using this information in a structured decision-making process, project teams will be able to make informed decisions about whether an item should be excavated or can be left in place.

**Step 2: Identify the goals of the data collection.** State how data will be used in meeting objectives and solving the problem. Identify study questions, including RA objectives. Define alternative outcomes.

Identify the principal study question: (Example) Based on current and anticipated future land use scenarios, which detected buried metal objects must be removed, and which ones may be left in place?

Identify alternative outcomes: (Example) To classify an object as a TOI and remove it, or to classify it as non-TOI and leave it in place.

State how the data will be used in solving the problem: (Example) Advanced geophysical classification will be used to 1) detect anomalies resulting from DMM, UXO, and other metallic debris and 2) classify anomalies so that informed decisions can be made as to whether the anomaly results from a TOI that

---

<sup>7</sup> Guidance on Systematic Planning Using the Data Quality Objectives Process, U.S. EPA, EPA QA/G-4, February 2006

<sup>8</sup> Technical Project Planning Process, U.S. Army Corps of Engineers, EM 200-1-2, August 1998



should be removed, or a non-TOI that may be left in place. Geophysical data collected using advanced EMI sensors in a dynamic mode will be used to initially detect and document the locations of subsurface anomalies. Geophysical data collected using advanced EMI sensors in a cued (static) mode will then be used to classify each anomaly as follows: 1) TOI, i.e., highly likely to be DMM or UXO; 2) Non-TOI, i.e., highly unlikely to be DMM or UXO; or 3) Inconclusive. Detected items classified as “TOI” and “inconclusive” will be targeted for removal. Items classified as non-TOI will be left in place. The results of geophysical detection and classification and the subsequent intrusive investigation must meet established DQOs to allow the anticipated land reuse to take place after the removal of TOI.

**Step 3: Identify information inputs.** Identify data and information needed to answer the study questions.

(Example)

- Up-to-date CSM summarizing site conditions based on previous studies (e.g., Preliminary Assessment (PA), Site Inspection (SI) and Remedial Investigation/Feasibility Study (RI/FS)). [See Worksheet #10]:
- Detection survey results, including:
  - Areas covered
  - System QC test results
  - Instrument Verification Strip (IVS) results
  - Surveyed validation seed and QC seed locations
  - Anomaly detections and responses
  - Data analysis results, including
    - Anomaly locations
    - Unique anomaly identification numbers
    - Z-component amplitude and dipole response for each anomaly
    - Detection survey data validation report
    - Detection survey data usability evaluation
    - Updated CSM
- Cued survey results, including:
  - System QC results
  - IVS results
  - Background data
  - Surveyed validation seed and QC seed locations and types
  - Unique anomaly identification numbers and locations
  - Site-specific munitions library
  - Definition of items representing unacceptable explosive hazard
  - Classification of anomalies with confidence metric
  - Cued survey data validation report
  - Cued survey data usability evaluation

- Updated CSM
- Intrusive investigation results, including
  - Excavation results (database)
  - Photos
  - Disposal records
  - Stop-Dig Threshold verification
  - Comparison of excavated “classification validation targets” to predictions
  - Final data usability evaluation
  - Final CSM

**Step 4: Define the boundaries of the project.** Specify the target population and characteristics of interest. Define spatial and temporal boundaries. [Discuss NAOC Comment 129]

Target population: (Example) The target population for this study includes the following MEC confirmed or suspected to exist in the study area:

**Table 11-1: Target Population**

Confirmed Munitions (including nomenclature, if known)	MEC Type (UXO, DMM, or both)	Munition Length	Observed Depth of Penetration (to center of mass)	Expected Detection Threshold
37mm (unknown mark/mod)	UXO			
75mm (unknown mark/mod)	UXO			
Suspected Munitions (including nomenclature, if known)	MEC Type (UXO, DMM, or both)			
60 mm mortar, M49A3	UXO			
155mm, M107	UXO			

Characteristics of interest: (Example) The characteristics of interest are those characteristics (e.g., size, symmetry, aspect ratio, object density, and wall thickness) that will allow classifiers to determine whether an anomaly is a TOI or non-TOI.

Spatial and temporal boundaries: Spatial boundaries include both the horizontal area and vertical depth of the study. Establishing the vertical boundary considers the maximum expected depth that objects are buried, the maximum predicted depth of future excavations and disturbances based on anticipated future land use, and detector limitations, i.e., the maximum depth at which sensors can collect meaningful data for specific munitions. Establishing spatial boundaries should consider any areas that

will be inaccessible to investigation for any reason (e.g., presence of power lines, structures, ponds, sensitive habitats, historic sites, and forested areas). Establishing temporal boundaries should consider seasonal conditions that could limit site access (e.g., periods of high rainfall, nesting seasons, etc.) Spatial and temporal boundaries should be depicted in the CSM (Worksheet #10).

(Example) This study is designed to detect and correctly classify all TOI exceeding the detection threshold and meeting measurement criteria within the established spatial boundaries. The detection threshold is a horizontal 37 mm projectile at 0.3 m below ground surface (bgs), which has been determined to be in the range of \_\_ to \_\_ millivolt (mV)/Ampere (A). This represents an anticipated minimum signal to noise ratio (SNR) of \_\_.

The horizontal boundaries of the project are defined by the boundary of the 7-acre treatability study area shown on Figure \_\_, excluding [list any areas excluded from the investigation]. The vertical boundary for each munition is the munition-specific maximum depth of detection based on the detection threshold discussed above. Vertical boundaries for each munition are shown on Figure \_\_.

**Step 5: Develop the Project Data Collection and Analysis Approach.** Define the parameter of interest, specify the type of inference (i.e., what criteria define anomaly detection and what criteria will distinguish between TOI and non-TOI), and develop the logic (decision rules) for drawing conclusions from findings.

(Example) This project will use the results from advanced geophysical sensors (polarizability decay curves or EMI signatures) and specialized geophysical modeling to classify target anomalies detected during the geophysical detection survey. Geophysical data from advanced sensors will be interpreted with physics-based models to estimate the physical attributes of the anomalies, and classifier models will be used to evaluate the likelihood that the anomalies are intact munitions. Anomalies will be classified into one of three categories described in Step 2 above. The final product will be a “ranked anomaly list” that classifies each anomaly, justifies the classification, and identifies whether a detected object will be removed or left in place. Anomalies on the list will be ranked in order of greatest likelihood to be a TOI to greatest likelihood to be a non-TOI, based on their confidence metrics.

### **Detection Phase**

**Parameters of interest:** (Example) Measurements with an amplitude  $\geq$ \_\_ and a SNR  $\geq$  \_\_.

**Type of inference:** (Example) Measurements meeting the criteria noted above will be considered to be potential TOI and selected as anomalies for further evaluation during the Cued Phase.

**Decision rules:** (Examples)

- If a response amplitude of  $\geq$ \_\_ mV/A is present in the detection data, and the signal to noise ratio is  $\geq$ \_\_, the anomaly will be selected and placed on the Amplitude Response Anomaly List

## **Cued Phase**

**Parameters of interest:** (Example) Spatial extent of detected anomaly, cued measurement SNR, inversion fit coherence, and inversion outputs of  $\beta_1$ ,  $\beta_2$ ,  $\beta_3$ , x, y, and z.

**Type of inference:** (Example) If any of the following three criteria are met, the anomaly will be selected as a TOI: 1) the polarizability matches (within specifications established on Worksheet #22) that of an item in the project-specific TOI library, 2) estimates of the size, shape, symmetry, and wall thickness calculated from the polarizability, indicates the item is long, cylindrical, and thick-walled, or 3) there is a group (cluster) of x or more anomalies having similar polarizabilities that, after investigation, are discovered to be TOI. Anomalies with poor inversion fit coherence that, after considering all available information, cannot be ruled as non-TOI (i.e., the data are inconclusive) will be added to the TOI list.

**Decision rules:** (Examples)

- If all or a portion of the study area is determined to have an anomaly density too high for cued analysis, then an alternative approach will be developed (factors for evaluating anomaly density are discussed in Worksheet #17).
- If the object is classified as TOI (highly likely to be a munition), then the object will be excavated.
- If the object is classified as non-TOI (highly unlikely to be a munition), then the object will be left in place.
- If the object is classified as inconclusive, then the object will be excavated.

**Step 6: Specify Project-specific Measurement Performance Criteria (MPC).** Considering Steps 1-5, derive project-specific MPCs that collected data will need to achieve to minimize the possibility of making erroneous decisions (i.e., concluding that a TOI is a non-TOI, or concluding that a non-TOI is a TOI). MPCs are the qualitative and quantitative specifications for accuracy, sensitivity, representativeness, completeness, and comparability that collected data must meet to satisfy the DQOs described in Steps 1 through 5, above. MPCs guide the development of the advanced geophysical classification survey design (which is developed during Step 7 and presented in Worksheet #17), and they are the criteria against which data usability will be evaluated at the end of the study. Project-specific MPCs are presented in Worksheet #12.

(Example) Project-specific MPCs are presented in Worksheet #12. Project-specific MPCs are the criteria that collected data must meet to satisfy the DQOs. Failure to achieve the MPCs may have an impact on end uses of the data, which will be discussed in the DUA Report.

**Step 7: Survey Design and Project Work Flow.** Develop a resource-effective design for collecting data that will meet the project-specific MPCs developed during Step 6. This step usually refers to Worksheet #17, which should describe the advanced geophysical classification process design and work flow in detail.

(Example) The MPCs established during Step 6 of the DQO process (documented in Worksheet #12) were used to develop the sample design, which is described in Worksheet #17. The sample design is broken down into a series of specific processes and data collection steps, termed DFW. Figure 17-1 provides a decision tree that will be used in the execution of the sample design, to evaluate the conformance of specific DFW to established MPC.

**QAPP Worksheet #12: Measurement Performance Criteria  
 (UFP-QAPP Manual Section 2.6.2)**

This worksheet documents the project-specific MPC in terms of data quality indicators (DQI) (i.e., accuracy, sensitivity, representativeness, completeness, and comparability) for advanced geophysical classification projects.<sup>9</sup> MPCs are the minimum performance specifications that the advanced geophysical classification survey design, including instruments and procedures, must meet to ensure collected data will satisfy the DQOs documented in Steps 1-5 on Worksheet #11. They are the criteria against which the detection survey, cued survey, and final DUAs will be conducted as documented on Worksheet #37. Minimum recommended MPCs applicable to the RA phase are presented in black text. Project teams may revise these MPCs or establish additional MPCs if necessary to achieve project-specific DQOs. The project-specific QAPP must explain and justify any changes to black text. An appendix may be used for this purpose.

**Table 12-1: Measurement Performance Criteria**

Measurement Performance Activity (or DFW)	Data Quality Indicator	Specification	Activity Used to Assess Performance
QC Seeding	Representativeness	Blind QC seeds will be placed at the site by the contractor. Blind QC seeds must be detectable as defined by the DQOs and located throughout the horizontal and vertical survey boundaries defined in the DQOs. [The blind seed plan should describe the number and types of blind QC seeds.] Blind QC seeds will be distributed such that the field team can be expected to encounter between one and three seeds per day per team.	Review of Production Area QC Seeding Report

<sup>9</sup> See Glossary for definitions of the data quality indicators.

**Table 12-1: Measurement Performance Criteria**

<b>Measurement Performance Activity (or DFW)</b>	<b>Data Quality Indicator</b>	<b>Specification</b>	<b>Activity Used to Assess Performance</b>
Detection Survey	Completeness	100% of the site is sampled.	Verification of conformance to measurement quality objectives (MQOs) for in-line spacing and cross-line spacing (see Worksheet #22)
Detection survey	Sensitivity	This worksheet must describe the project-specific detection threshold. (Example) A detection threshold of $\geq 1.7$ mV/A and $SNR \geq 5$ is required to detect a [37 mm projectile] lying horizontally at a depth of [0.3 m].	Initial and ongoing Instrument Verification strip (IVS) surveys Blind QC and validation seed detection Analysis of background variability across the site
Detection survey	Accuracy/ Completeness	100% of validation seeds must be detected.	Review of validation seed detection results per survey unit
Detection survey	Completeness/ Comparability	Complete project-specific databases and target lists delivered.	Data verification/data validation
Classification survey	Completeness/ Comparability	Library must include signatures for all munitions known or suspected to be present at the site, as listed in the CSM.	Verification of site-specific library
Classification survey	Representativeness/ Accuracy	Background data will be collected at least once every two hours of cued survey data collection. Background locations will be selected such that background data will be representative of the various subsurface conditions expected to be encountered within each survey unit at the site.	Data verification/data validation

**Table 12-1: Measurement Performance Criteria**

<b>Measurement Performance Activity (or DFW)</b>	<b>Data Quality Indicator</b>	<b>Specification</b>	<b>Activity Used to Assess Performance</b>
Classification survey	Completeness	All detected anomalies classified as: 1. TOI 2. Non-TOI 3. Inconclusive	Data verification
Classification survey	Accuracy/ Completeness	Cued survey must correctly classify 100% of all validation seeds.	Review of validation seed classification results
Classification survey	Accuracy	100% of predicted non-TOI that are intrusively investigated are confirmed to be non-TOI.	Visual inspection of recovered items from classification validation
Intrusive Investigation (classification validation)	Accuracy	Inversion results correctly predict one or more physical properties (e.g. size, symmetry, or wall thickness) of the recovered items (specific tests and test objectives established during project planning).	Visual inspection and qualitative evaluation of items recovered during classification validation
Intrusive Investigation	Completeness/ Comparability	Complete project-specific database including records reconciling inversion results to the physical properties of the recovered items.	Data verification Data validation



**QAPP Worksheet #13: Secondary Data Uses and Limitations  
 (UFP-QAPP Manual Section 2.7)**

This worksheet should be used to identify sources of secondary data (i.e., data generated for purposes other than this specific project or data pertinent to this project generated under a separate QAPP) and summarize information relevant to their uses for the current project. This worksheet should describe specifically how all secondary data will be used. The project team needs to carefully evaluate the quality of secondary data (in terms of accuracy, sensitivity, representativeness, comparability, and completeness) to ensure they are of the type and quality necessary to support their intended uses. Examples of secondary data include the following: sampling and testing data collected during previous investigations, historical data, background information, interviews, modeling data, photographs, aerial photographs, topographic maps, and published literature. When evaluating the reliability of secondary data and determining limitations on their uses, consider the source of the data, the time period during which they were collected, data collection methods, potential sources of uncertainty, the type of supporting documentation available, and the comparability of data collection methods to the currently proposed methods. Examples are provided below.

**Table 13-1: Secondary Data Uses and Limitations**

Data type	Source	Data uses relative to current project	Factors affecting the reliability of data and limitations on data use
Infrastructure locations			
Range history			
Munitions use and disposal			

**QAPP Worksheet #14/16: Project Tasks & Schedule  
 (UFP-QAPP Manual Section 2.8.2)**

The QAPP should include a project schedule showing specific tasks, the person or group responsible for their execution, and planned start and end dates. The following template may be used or a Gantt chart can be attached and referenced. Examples of activities that should be listed include key on-site and off-site activities. Any critical steps and dates should be highlighted.

**Table 14-1: Project Tasks and Schedule**

DFW	Activity	Responsible party	Planned start date	Planned completion date	Deliverable(s)	Deliverable due date
1	Site Preparation					
2	Seeding & IVS Construction					
3 & 4	Detection Survey					
5	Data Processing (Detection Phase)					
5	Data Verification and Validation (Detection Phase)					
5	Data Usability Assessment (Detection Phase)					

**Table 14-1: Project Tasks and Schedule**

<b>DFW</b>	<b>Activity</b>	<b>Responsible party</b>	<b>Planned start date</b>	<b>Planned completion date</b>	<b>Deliverable(s)</b>	<b>Deliverable due date</b>
6 & 7	Cued Survey					
8	Validate Advanced Sensor Data					
9	Conduct Data Processing					
10	Anomaly Classification					
10	Data Usability Assessment (Cued Phase) & Dig/no-Dig Decisions					
11	Intrusive Investigation					
12	Threshold Verification					
12	Classification Validation					

**Table 14-1: Project Tasks and Schedule**

<b>DFW</b>	<b>Activity</b>	<b>Responsible party</b>	<b>Planned start date</b>	<b>Planned completion date</b>	<b>Deliverable(s)</b>	<b>Deliverable due date</b>
13	Data Usability Assessment (Final)					
13	Final Report Preparation					

### **QAPP Worksheet #17: Survey Design and Project Work Flow (UFP-QAPP Manual Section 3.1.1)**

This worksheet describes and justifies the design for both the detection and cued surveys. It documents Step 7 of the DQO process. If a munitions response site consists of multiple areas to be surveyed, then a separate survey design section or worksheet should be completed for each area. Factors that will influence the survey design include the size of the site, types and expected distribution of munitions and other debris present, the terrain, and other site conditions that could limit the ability of field teams or equipment to access portions of the site.

The survey design and project work flow must include the following:

1. A map showing physical boundaries for the area(s) under study.
2. The basis for dividing the site into survey units.
3. A decision-logic diagram (See Figure 17-1 for an example)
4. Concise descriptions for each DFW (SOPs containing detailed procedures must be included in an appendix to the project-specific QAPP)
5. Contingencies in the event field conditions are different than expected and could have an effect on the survey design (e.g. a portion of the site is inaccessible at the time the site work is planned to occur, or anomaly density is higher than expected.)
6. Points in the process at which lead organization, regulatory, and stakeholder interface will occur, as agreed upon during project planning.

Project Work Flow: This section should provide concise descriptions for each DFW and highlight government (lead organization and/or regulatory) inspection/oversight activities, key deliverables, and decision points, as they have been agreed upon during project planning. Worksheet #17 should reference other worksheets or SOPs containing detailed procedures. (In all cases, SOPs must be provided in an appendix to the project-specific QAPP.) Project teams may modify this work flow description to consolidate DFW or provide further break-down of DFW, as necessary to accommodate project-specific specifications.

DFW 1: Conduct site preparation (contractor and lead organization): Describe activities that must be completed prior to conducting site work (e.g., surface clearance, surface sweep, construction of silt fences or other barriers, if needed (for example, to prevent access by or exposure to potential receptors during site activities), and activities to preserve cultural resources or sensitive habitats, if needed. Describe procedures used to establish and document survey boundaries, including the use of control points for data positioning, and the establishment of survey units.

Documentation: [Surface Sweep Technical Memorandum](#)

[Example] Contractor: The contractor will conduct site preparation activities in the survey area as well as any areas needed for equipment ingress/egress. The contractor will conduct a surface sweep to remove all exposed or partially exposed metallic objects that are equal to or greater than 5.0 cm in

length in any direction. The contractor will document the type, quantity, and estimated mass of objects removed. Following the lead organization's inspection and acceptance of the surface sweep, the contractor will [describe remaining site preparation activities]. Detailed procedures are contained in SOP(s) \_\_ [list relevant SOPs].

Lead organization: Following the surface sweep, the lead organization (or designee) will review the Surface Sweep Technical Memorandum and visually inspect the site.

DFW 2: Conduct validation seeding, Quality Control (QC) seeding, and construct IVS (contractor and lead organization): Contractor: Describe the contractor's placement of blind QC seeds and construction of the IVS. Provide the rationale for the types, number, and placement of QC seeds. Describe procedures for constructing the IVS, including the number, descriptions, depths, and orientation of targets. This step should reference the draft Verification and Validation Plan, which should be referenced on Worksheet #36 and provided as an appendix to the QAPP.

Lead organization: Describe the placement of validation seeds by or on behalf of the lead organization.

Documentation: [QC Seeding Plan, IVS Plan, Draft Verification and Validation Plan](#)

DFW 3: Assemble and verify correct operation of geophysical sensor to be used for the detection survey (contractor): Describe procedures to be used to assemble and verify correct operation of the detection instrument (initial function test). Describe procedures for testing sensor operation at the IVS.

Documentation: [Instrument Assembly QC Checklist; IVS Memorandum](#)

Decision point: [Have MQOs been achieved?](#)

DFW 4: Conduct detection survey (contractor): Describe the equipment and procedures that will be used to conduct the detection survey, including ongoing field QC activities (e.g. ongoing function tests). Describe requirements for detection and positioning. Describe and provide the rationale for coverage specifications (based on sensor geometry and sizes of targets).

Documentation: [Daily IVS Summaries; Daily QC Reports](#)

DFW 5: Conduct data processing and document locations of anomalies (contractor and lead organization): Contractor: Describe the procedures that will be used to process the detection data, validate the detection data (Worksheet #35 may be referenced), document locations to be used for background data collection during cued data collection, and select anomalies for cued data collection. If using an advanced sensor for the detection survey and informed source selection (IFS), describe the procedure and criteria for eliminating anomalies from further consideration (e.g., evaluating dipole fit coherence and thresholds for size and decay rates). To verify the size and decay rate thresholds, identify an additional 200 anomalies below these thresholds to be included on the list of anomalies selected for cued data collection.

Lead organization: Because the cued data collection will be performed only at the locations of anomalies selected during this step, it is critical that the detection survey data validation be accepted by

the lead organization, before the cued data collection begins. (Data validation is discussed in Worksheet #35). Once the lead organization has accepted the data validation report, the project team should conduct a detection survey DUA before proceeding to the cued phase. The DUA is discussed in Worksheet #37.

Documentation: [Target Selection Technical Memorandum \(data analysis, anomaly density, list of selected anomalies, recommended background locations\), maps \(depicting data and coverage, anomaly density, and selected anomalies\), Weekly QC reports, and Detection Survey DUA Report](#)

Decision point: Is anomaly density acceptable for cued survey? Have MQO's been achieved

**DFW 6: Assemble advanced geophysical sensor and test sensor at IVS (contractor):** Describe procedures to be used to assemble the advanced geophysical sensor, and verify its correct operation (initial function test and initial cued survey IVS). Reassess the appropriateness of the IVS.

Documentation: [Instrument Assembly Checklist; Cued Survey IVS Memorandum](#)

Decision point: Have MQOs been achieved?

**DFW 7: Collect cued data (contractor):** Describe procedures for locating each anomaly identified for cued data collection, positioning the sensor, collecting the cued data, and conducting field inversions (i.e., quick checks by field personnel to confirm the acquired signal is representative of the target anomaly). Describe the procedures and frequency for conducting ongoing function tests and collecting cued background data. Describe procedures and frequency for verifying ongoing operations at the IVS and conducting field QC.

Documentation: [Daily IVS Summaries; Daily QC Reports](#)

Decision point: Have MQOs been achieved?

**DFW 8: Validate advanced sensor data (contractor and lead organization):** Contractor: Describe the procedures for validating cued survey data prior to inversion. If using advanced anomaly selection, this would include the process for verifying the size and decay rate thresholds. The contractor typically conducts validation each day of data collection and generates a weekly QC report for review by the lead organization.

Lead organization: Review and accept weekly QC reports

Documentation: [Database \(raw data and metadata\), Weekly QC Reports](#)

Decision point: Have MQOs been achieved?

**DFW 9: Conduct data processing (contractor):** Describe procedures for removing the effects of background signals on the advanced sensor data to isolate the signature from the buried metal object. Describe the software and procedures for inverting the data to generate polarizability decay curves that will be the basis for 1) library matching, 2) identifying clusters, and 3) predicting the size, shape, and wall thickness of buried objects.

Documentation: [Database \(Inversion Results\)](#)

Decision point: [Have MQOs been achieved?](#)

**DFW 10: Classify anomalies and make dig/no-dig decisions (contractor and lead organization)**

**Contractor:** Describe procedures and factors considered in classifying anomalies. The classification process considers how well the signature matches the library data (Worksheet #22 contains specifications for library fit coherence). In cases where the signature does not match library data but appears to either 1) fit that of a cluster (i.e., numerous similar signatures consistent with a potential TOI not contained in the library) or 2) predict properties consistent with those of a munition, the contractor will use information in the CSM (e.g., site history and uses, and known types and distribution of munitions) to assist with the classification process.

Objects will be classified into one of the following three categories, and the project team will make a dig/no-dig decision on each:

1. TOI (Highly likely to be MEC);
2. Non-TOI (Highly unlikely to be MEC);
3. Inconclusive (Data cannot be analyzed).

Classified objects will be placed on a ranked anomaly list, arranged in order from highest likelihood the object is a TOI to highest likelihood the object is a non-TOI. Objects classified as inconclusive will be included on the ranked anomaly list as potential TOI, and therefore, they will be included on the Dig List.

The contractor identifies the threshold between TOI and non-TOI (i.e., the last TOI on the Dig List), and an additional 200 “threshold verification” targets to add to the Dig List. [Note: threshold verification targets are selected sequentially below the TOI/non-TOI threshold].

**Lead organization:** The lead organization reviews and accepts the classification results.

**Project team:** The project team conducts the cued survey DUA, selects the 200 classification validation targets, reviews the draft Verification and Validation Plan and makes changes as necessary. [Note: selection of the classification validation targets can be either random or judgmental.]

Documentation: [TOI/non-TOI classification spreadsheet; library match results, figures and maps, Dig List, Cued Survey DUA Report, Final Verification and Validation Plan](#)

Decision point: [Are all QC seeds on the dig list? Are all validation seeds on the dig list correctly classified? Have MPCs been achieved?](#)

**DFW 11: Excavate buried objects (contractor):** Describe procedures to reacquire and flag anomalies selected for intrusive investigation and investigate anomalies. This includes selecting the threshold verification targets and the classification validation targets.

Documentation: [Database of excavation results, photographs, weekly QC reports, disposal reports](#)



DFW 12: Verify the threshold and verify recovered non-TOI validation targets are consistent with predictions based on advanced sensor data (contractor and project team): Describe procedures for comparing excavated objects against the classification spreadsheet. If necessary, adjust the TOI/non-TOI threshold. If necessary identify additional threshold verification and classification validation targets such that all 400 targets represent non-TOI targets on the ranked anomaly list below the final threshold.

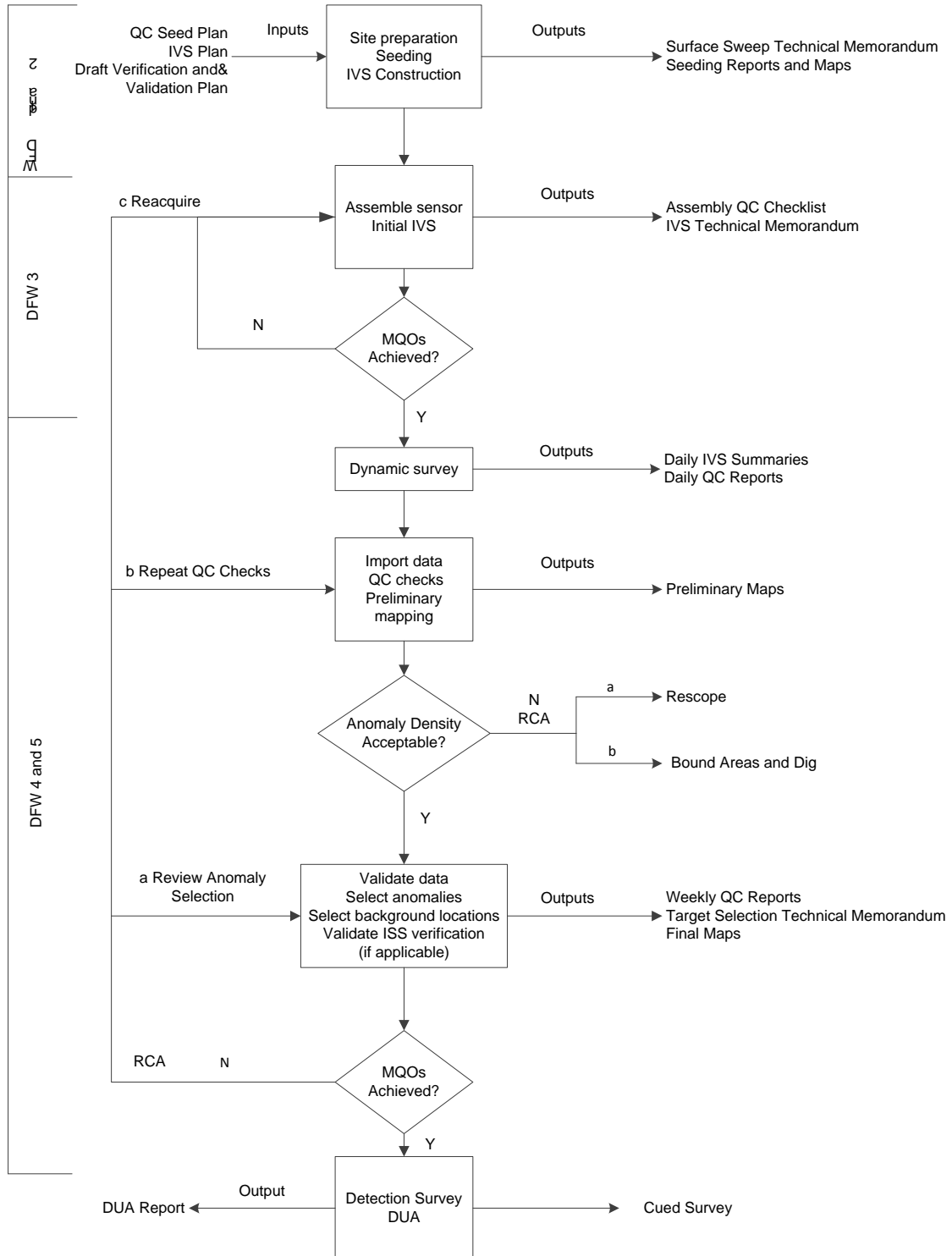
Documentation: [Comparison results](#)

Decision point: [Was the stop-dig threshold correct? Are all excavated objects consistent with predictions?](#)

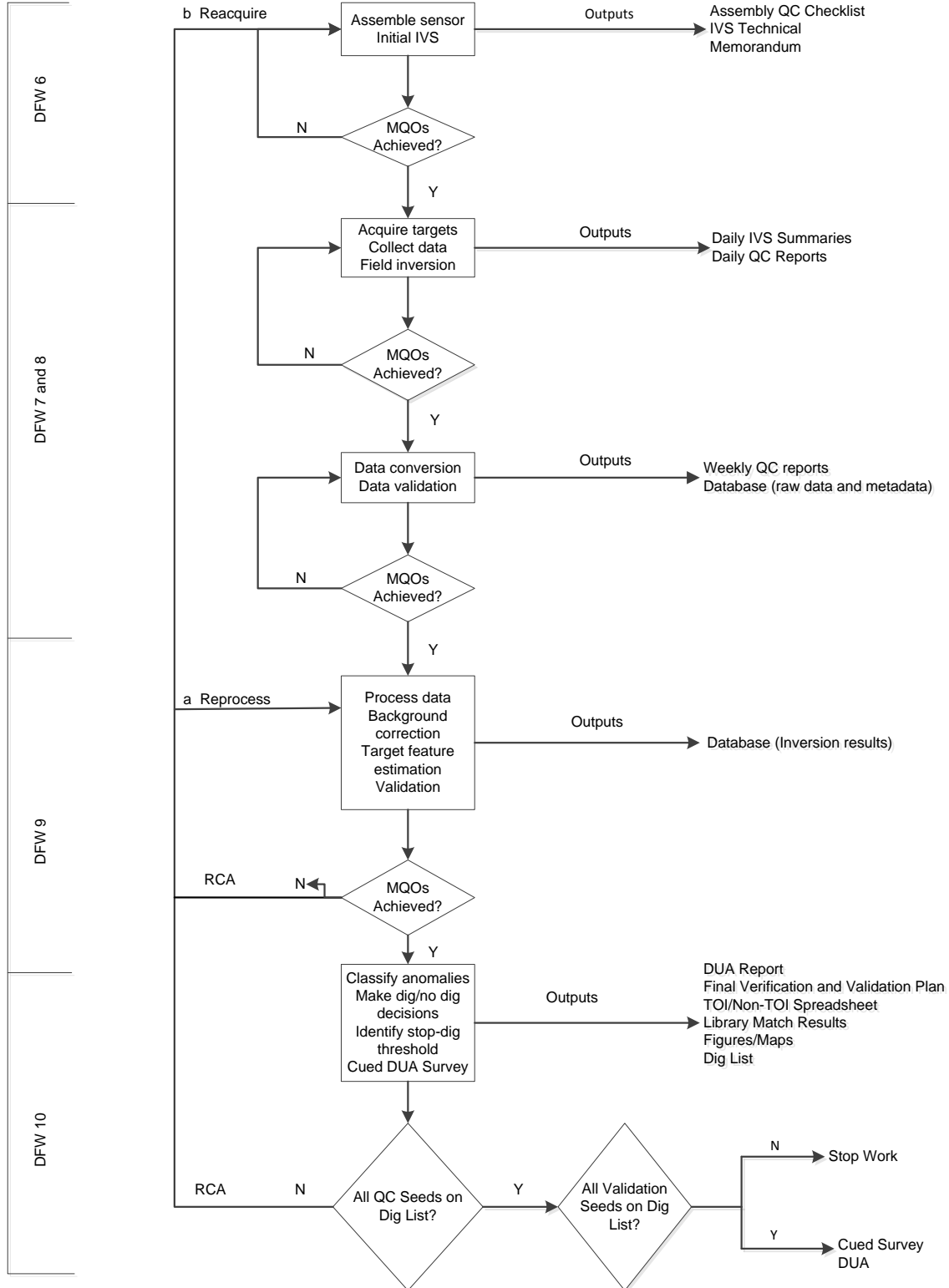
DFW 13: Conduct Final DUA: Briefly describe procedures to conduct the final DUA. (Refer to Worksheet #37 for detailed procedures.

Documentation: [Updated CSM, Final DUA, Final Report](#)

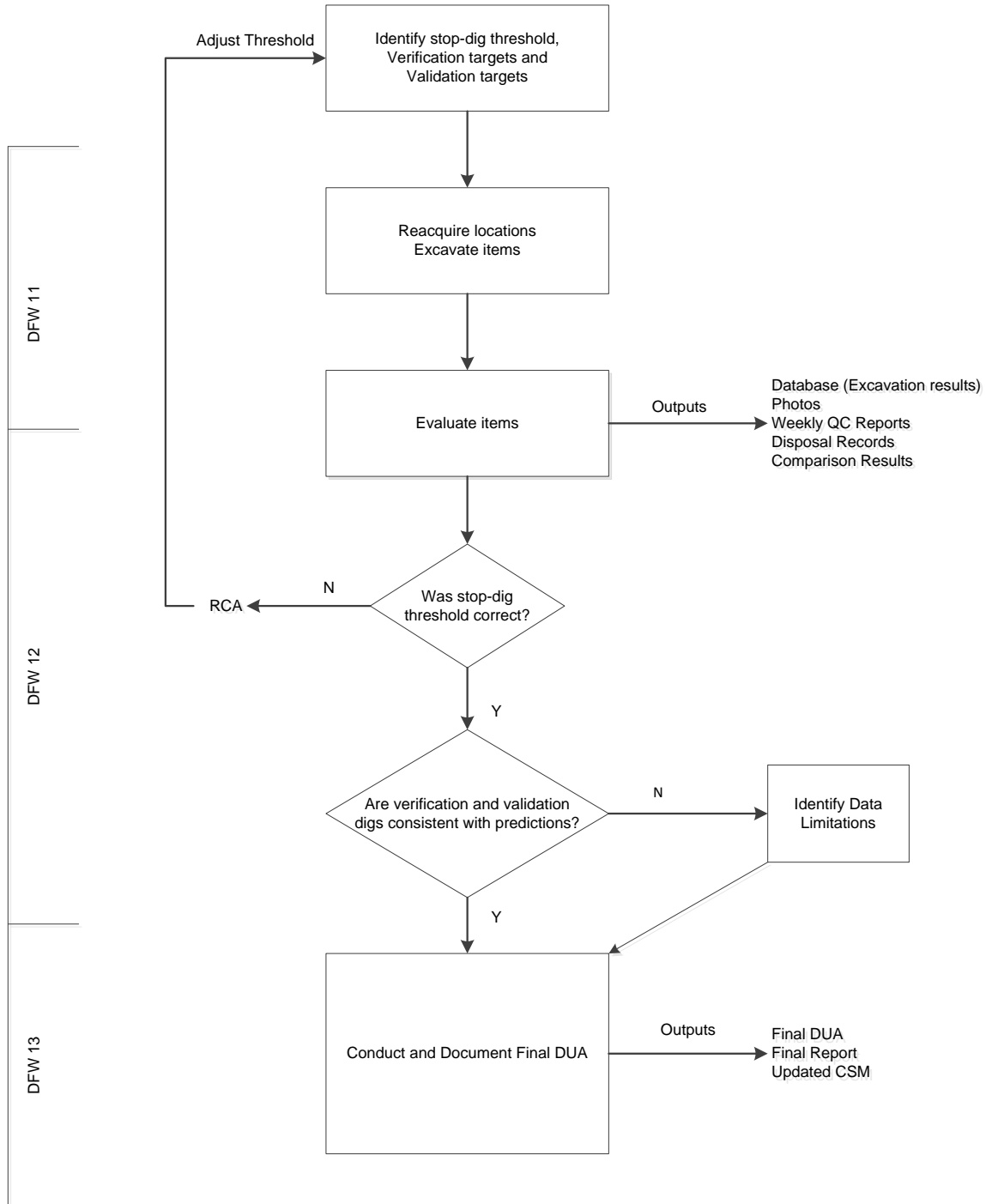
**Figure 17-1: Advanced Geophysical Classification Decision Tree  
 Preliminary Tasks and Anomaly Detection Survey**



## Cued Survey



# Intrusive Investigation



**QAPP Worksheet #22: Equipment Testing, Inspection, and Quality Control  
 (UFP-QAPP Manual Section 3.1.2.4)**

This worksheet documents procedures for performing testing, inspections and quality control for all field data collection activities. References to the applicable definable feature of work (DFW) and standard operating procedures must be included. Failure response must include a root cause analysis (RCA) to determine the appropriate CA. Examples are provided in blue text. Minimum recommended specifications are provided in black text. The rationale for any changes to black text must be specifically identified, documented and concurred upon by the project team. An appendix may be used for this purpose.

**Table 22-1: Detection Survey (instrument: \_\_\_\_\_)**

<b>Measurement Quality Objective</b>	<b>DFW/SOP Reference</b>	<b>Frequency</b>	<b>Responsible Person/ Report Method/ Verified by</b>	<b>Acceptance Criteria</b>	<b>Failure Response</b>
Verify correct assembly		Once following assembly	Field Team Leader/ instrument assembly checklist/Project Geophysicist	As specified in Assembly checklist	RCA/CA: Make necessary adjustments, and re-verify
Initial Instrument Function Test (TEMTADS) (Instrument response amplitudes)		Once following assembly	Field Geophysicist/ Initial IVS Memorandum/ Project Geophysicist	Response (mean static spike minus mean static background) within 20% of predicted response for all transmit/receive (Tx/Rx) combinations	RCA/CA: Make necessary adjustments, and re-verify

**Table 22-1: Detection Survey (instrument: \_\_\_\_\_ )**

Measurement Quality Objective	DFW/SOP Reference	Frequency	Responsible Person/ Report Method/ Verified by	Acceptance Criteria	Failure Response
Initial Instrument Function Test (MetalMapper) (five measurements over a small ISO80 target, one in each quadrant of the sensor and one directly under the center of the array). Derived polarizabilities for each measurement are compared to the library.		Once following assembly	Field Team Leader/ Instrument Assembly Checklist/ Project Geophysicist	Library match metric $\geq 0.95$ for each of the five sets of inverted polarizabilities	RCA/CA: Make necessary adjustments, and re-verify
Initial Instrument Function Test (EM61)		Once following assembly	Field Geophysicist/ Initial IVS Memorandum/ Project Geophysicist	Response (mean static spike minus mean static background) within 20% of predicted response for all channels	RCA/CA: Make necessary adjustments, and re-verify
Initial detection survey positioning accuracy (IVS) [NAOC 101]		Once prior to start of detection survey data acquisition	Project Geophysicist/ IVS Memorandum/QC Geophysicist	Derived positions of IVS target(s) are within 25cm of the ground truth locations	RCA/CA: Make necessary adjustments, and re-verify

**Table 22-1: Detection Survey (instrument: \_\_\_\_\_ )**

<b>Measurement Quality Objective</b>	<b>DFW/SOP Reference</b>	<b>Frequency</b>	<b>Responsible Person/ Report Method/ Verified by</b>	<b>Acceptance Criteria</b>	<b>Failure Response</b>
Ongoing Instrument Function Test (Instrument response amplitudes) (TEMTADS)		Beginning and end of each day and each time instrument is turned on	Field Team Leader/ running QC summary (Excel/Geosoft) /Project or QC Geophysicist	Response (mean static spike minus mean static background) within 20% of predicted response for all Tx/Rx combinations	RCA/CA: Make necessary repairs and re-verify
Ongoing Instrument Function Test (MetalMapper)		Beginning and end of each day and each time instrument is turned on	Field Team Leader/ running QC summary/Project or QC Geophysicist	Response (mean static spike minus mean static background) within 20% of predicted response for all Tx/Rx combinations	RCA/CA: Make necessary repairs and re-verify
Ongoing Instrument Function Test (EM61)		Beginning and end of each day and each time instrument is turned on	Field Team Leader/ running QC summary/Project or QC Geophysicist	Response (mean static spike minus mean static background) within 20% of predicted response for all channels	RCA/CA: Make necessary repairs and re-verify
Ongoing detection survey positioning precision (IVS)		Beginning and end of each day	Project Geophysicist / running QC summary/QC Geophysicist	Derived positions of IVS target(s) within 25 cm of the average locations	RCA/CA

**Table 22-1: Detection Survey (instrument: \_\_\_\_\_)**

Measurement Quality Objective	DFW/SOP Reference	Frequency	Responsible Person/ Report Method/ Verified by	Acceptance Criteria	Failure Response
In-line measurement spacing (TEMTADS)		Verified for each survey unit using [describe tool to be used] based upon monostatic Z coil data positions	Project Geophysicist/ running QC summary/ QC Geophysicist	100% ≤ 0.20m between successive measurements	RCA/CA CA assumption: data set fails, (recollect portions that fail)
In-line measurement spacing (MetalMapper)		Verified for each survey unit using [describe tool to be used] based upon monostatic Z coil data positions	Project Geophysicist/ running QC summary/ QC Geophysicist	100% ≤ 0.25m between successive measurements	RCA/CA
In-line measurement spacing (EM61)		Verified for each survey unit using [describe tool to be used] based upon monostatic Z coil data positions	Project Geophysicist/ running QC summary/ QC Geophysicist	100% ≤ 0.25m between successive measurements	RCA/CA



**Table 22-1: Detection Survey (instrument: \_\_\_\_\_ )**

Measurement Quality Objective	DFW/SOP Reference	Frequency	Responsible Person/ Report Method/ Verified by	Acceptance Criteria	Failure Response
Coverage (TEMTADS)		Verified for each survey unit using [describe tool to be used] based upon monostatic Z coil data	Project Geophysicist/running QC summary and survey unit validation report/QC Geophysicist	100% at ≤0.7m cross-track measurement spacing (excluding site specific access limitations, e.g., obstacles, unsafe terrain)	RCA/CA
Coverage (MetalMapper)		Verified for each survey unit using [describe tool to be used] based upon monostatic Z coil data	Project Geophysicist/running QC summary and survey unit validation report/QC Geophysicist	100% at ≤0.7m cross-track measurement spacing (excluding site specific access limitations, e.g., obstacles, unsafe terrain)	RCA/CA
Coverage (EM61 using electronic positioning)		Verified for each survey unit using [describe tool to be used] based upon monostatic Z coil data	Project Geophysicist/running QC summary and survey unit validation report/QC Geophysicist	100% at project design cross-track measurement spacing (excluding site specific access limitations, e.g., obstacles, unsafe terrain)	RCA/CA
Sensor Tx current (TEMTADS)		Per measurement	Field Team Leader/running QC summary/Project Geophysicist	Current must be ≥5.5A	RCA/CA: out of spec data rejected
Sensor Tx current (MetalMapper)		Per measurement	Field Team Leader/running QC summary/Project Geophysicist	Current must be ≥3.5A	RCA/CA: out of spec data rejected

**Table 22-1: Detection Survey (instrument: \_\_\_\_\_ )**

<b>Measurement Quality Objective</b>	<b>DFW/SOP Reference</b>	<b>Frequency</b>	<b>Responsible Person/ Report Method/ Verified by</b>	<b>Acceptance Criteria</b>	<b>Failure Response</b>
Detection survey repeatability (EM61)		Evaluated by survey unit	Project Geophysicist/running QC summary and survey unit validation report/QC Geophysicist	QC seed response must be >75% of minimum predicted response at geometric center of anomaly	RCA/CA
Detection survey performance		Evaluated by survey unit	QC Geophysicist/ survey unit validation report/ lead organization QA Geophysicist	All blind QC seeds must be detected and positioned within 40 cm radius of ground truth	RCA/CA
Valid position data		Per measurement	Field Team Leader/running QC summary/Project Geophysicist	GPS status flag indicates real-time kinematic (RTK) fix and dilution of precision (DOP) less than 4.0	RCA/CA: Out-of-spec data rejected
Valid orientation data		Per measurement	Field Team Leader/running QC summary/Project Geophysicist	Orientation data reviewed and appear reasonable within bounds appropriate to site	RCA/CA: Unreasonable data rejected
Size and decay rate threshold verification (when informed source selection is used)		Collect cued data from an additional 200 anomalies excluded on the basis of advanced anomaly selection	QC Geophysicist	Cued data analysis confirms 100% of excluded anomalies are non-TOI	RCA/CA

**Table 22-2: Cued Survey (instrument: \_\_\_\_\_; classification tool: \_\_\_\_\_)**

<b>Measurement Quality Objective</b>	<b>DFW/SOP Reference</b>	<b>Frequency</b>	<b>Responsible Person/ Report Method/ Verified by:</b>	<b>Acceptance Criteria</b>	<b>Failure Response</b>
Verify correct assembly		Once following assembly	Field Team Leader/ instrument assembly checklist/Project Geophysicist	As specified in instrument assembly checklist	RCA/CA: Make necessary adjustments, and re-verify
Initial sensor function test (TEMTADS)		Once following assembly	Field Team Leader/ instrument assembly checklist/Project Geophysicist	Response (mean static spike minus mean static background) within 20% of predicted response for all Tx/Rx combinations	RCA/CA: make necessary repairs/ adjustments and re- verify
Initial instrument function test (MetalMapper) (five measurements over a small ISO80 target, one in each quadrant of the sensor and one directly under the center of the array). Derived polarizabilities for each measurement are compared to the library		Once following assembly	Field Team Leader/ instrument assembly checklist/ Project Geophysicist	Library match metric $\geq$ 0.95 for each of the five sets of inverted polarizabilities	RCA/CA: make necessary repairs/ adjustments and re- verify

**Table 22-2: Cued Survey (instrument: \_\_\_\_\_; classification tool: \_\_\_\_\_)**

Measurement Quality Objective	DFW/SOP Reference	Frequency	Responsible Person/ Report Method/ Verified by:	Acceptance Criteria	Failure Response
Initial IVS background measurement and background verification (five background measurements, one centered at the flag and one offset at least ½ sensor spacing in each cardinal direction)		Once during initial system IVS test	Field Team Leader/ Initial IVS memorandum/ Project Geophysicist	All five measurements (decay amplitude) within the noise level of each other and library match from all four offset measurements >0.9	RCA/CA: reject/replace BG location
Initial derived polarizabilities accuracy (IVS)		Once during initial system IVS test	Project Geophysicist/ Initial IVS memorandum/ QC Geophysicist	Library Match metric ≥ 0.9 for each set of inverted polarizabilities	RCA/CA
Derived target position accuracy (IVS)		Once during initial system IVS test	Project Geophysicist/ Initial IVS Memorandum/QC Geophysicist	All IVS item fit locations within 0.25m of ground truth locations	RCA/CA
Ongoing derived polarizabilities precision (IVS)		Beginning and end of each day as part of IVS testing	Project Geophysicist/ tracking summary/QC Geophysicist	Library Match to initial polarizabilities metric ≥ 0.9 for each set of three inverted polarizabilities	RCA/CA
Ongoing derived target position precision (IVS)		Beginning and end of each day as part of IVS testing	Project Geophysicist/ tracking summary/QC Geophysicist	All IVS items fit locations within 0.25m of average of derived fit locations	RCA/CA

**Table 22-2: Cued Survey (instrument: \_\_\_\_\_; classification tool: \_\_\_\_\_)**

Measurement Quality Objective	DFW/SOP Reference	Frequency	Responsible Person/ Report Method/ Verified by:	Acceptance Criteria	Failure Response
Initial measurement of production area background locations and background verification (five background measurements: one centered at the flag and one offset at least ½ sensor spacing in each cardinal direction)		Once per background location	Field Team Leader/ background location report/Project Geophysicist	All five measurements (decay amplitude) within the noise level of each other and library match from all four offset measurements >0.9	RCA/CA: reject BG location and find alternate
Ongoing production area background measurements		Background data collected a minimum of every two hours during production	Field Team Leader/failures noted in field log and tracking summary/Project Geophysicist	Original and ongoing measurements at each location differ by a factor of five or less.	RCA/CA: document environmental changes. Project Geophysicist must approve before proceeding.
Ongoing instrument function test (TEMTADS)		Each time instrument is restarted	Field Team Leader/tracking summary/Project Geophysicist	Response (mean static spike minus mean static background) within 20% of predicted response for all Tx/Rx combinations	RCA/CA: make necessary repairs and re-verify
Ongoing instrument function test (MetalMapper)		Each time instrument is turned on	Field Team Leader/tracking summary/ Project Geophysicist	Response within 20% of predicted response	RCA/CA: Make necessary repairs and re-verify
Transmit current levels (TEMTADS)		Evaluated for each sensor measurement	Field Team Leader/tracking summary/ Project Geophysicist	Current must be ≥5.5A	RCA/CA: stop data acquisition activities until condition corrected

**Table 22-2: Cued Survey (instrument: \_\_\_\_\_; classification tool: \_\_\_\_\_)**

Measurement Quality Objective	DFW/SOP Reference	Frequency	Responsible Person/ Report Method/ Verified by:	Acceptance Criteria	Failure Response
Transmit current levels (MetalMapper)		Evaluated for each sensor measurement	Field Team Leader/ tracking summary/ Project Geophysicist	Current must be $\geq 3.5A$	RCA/CA: stop data acquisition activities until condition corrected
Confirm all background measurements are valid		Evaluated for each background measurement	Project Geophysicist/ Background summary/ QC Geophysicist	Ensure background variation does not impact ability to classify correctly	RCA/CA: BG measurement rejected and removed from active BG measurements
Confirm adequate spacing between units (TEMTADS)		Evaluated at start of each day (or grid)	Field Team Leader/ Field Logbook/ Project Geophysicist	Minimum separation of 50m	RCA/CA: Recollect all coincident measurements
Confirm adequate spacing between units (MetalMapper)		Evaluated at start of each day (or grid)	Field Team Leader/ Field Logbook/ Project Geophysicist	Minimum separation of 25m	RCA/CA: Recollect all coincident measurements
Confirm inversion model supports classification (1 of 3)		Evaluated for all models derived from a measurement (i.e. single item and multi-item models)	Project Geophysicist/ Measurement QC summary/ QC Geophysicist	Derived model response must fit the observed data with a fit coherence $\geq 0.8$ <sup>10</sup>	Follow procedure in SOP or RCA/CA
Confirm inversion model supports classification (2 of 3)		Evaluated for derived target	Project Geophysicist/ Measurement QC summary/ QC Geophysicist	Fit location estimate of item $\leq 0.4m$ from center of sensor	Follow procedure in SOP or RCA/CA

<sup>10</sup> Fit coherence is defined as the square of the correlation coefficient between data and model

**Table 22-2: Cued Survey (instrument: \_\_\_\_\_; classification tool: \_\_\_\_\_)**

Measurement Quality Objective	DFW/SOP Reference	Frequency	Responsible Person/ Report Method/ Verified by:	Acceptance Criteria	Failure Response
Confirm inversion model supports classification (3 of 3)		Evaluated for all seeds	QC Geophysicist/ Measurement Inversion model QC summary/lead organization QA Geophysicist	100% of predicted seed positions $\leq$ 0.25m radially from known position (x, y). $Z \leq .15m$ ).	RCA/CA
Confirm reacquisition GPS precision		Daily	UXO tech or field tech/ Daily QC Report/ Project Geophysicist	Benchmark positions repeatable to within 10cm	RCA/CA
Classification performance		Evaluated for all seeds	QC Geophysicist; USACE QA Geophysicist/ Ranked Dig List/ USACE QA Geophysicist	100% of QC and validation seeds placed on dig list	RCA/CA

**Table 22-3: Intrusive Investigation**

Measurement Quality Objective	DFW/SOP Reference	Frequency	Responsible Person/ Report Method/ Verified by:	Acceptance Criteria	Failure Response
Confirm derived features match ground truth (1 of 2)		Evaluated for all recovered items	Project Geophysicist/ Measurement QC Summary or intrusive database/QC Geophysicist	100% of recovered (excluding inconclusive category) item positions $\leq$ 0.25m from predicted position (x, y).	RCA/CA
Confirm derived features match ground truth (2 of 2)		Evaluated for all recovered items	UXO Dig Team/ Dig List and intrusive database/ Project or QC Geophysicist	100% of recovered object size estimates (excluding inconclusive category) qualitatively match predicted size	RCA/CA
Verification of TOI/non-TOI threshold		Dig 200 anomalies beyond last TOI on Dig List	Project Geophysicist/ Verification and Validation Report/QC Geophysicist	100% of predicted non-TOI intrusively investigated are non-TOI	RCA/CA. Adjust threshold
Classification validation		Random selection of 200 non-TOI	Project Geophysicist/ Verification and Validation Report/ QC Geophysicist	100% of predicted non-TOI qualitatively matches predicted size/shape	RCA/CA. Document in DUA



**QAPP Worksheet #29: Data Management, Project Documents, and Records  
 (UFP-QAPP Manual Section 3.5.1)**

This worksheet provides 1) minimum specifications for all data management tasks and deliverables, and 2) procedures for controlling project documents, records, and databases. Where applicable, specific versions or dates of software used should be documented. Its purpose is to ensure data completeness, data integrity, traceability and ease of retrieval.

**Part 1: Data Management Specifications**

Computer Files and Digital Data: All final document files, including reports, figures, and tables, will be submitted in electronic format on CD-ROM or as specified by the DoD client. Data management and backup must be performed in accordance with the contractor’s documented quality system.

TOI Library: This worksheet must document the version (date) of the DoD TOI library used and describe or reference procedures to be used to update the library. The TOI library used must be included in data deliverables.

**Part 2: Control of Documents, Records, and Databases**

**Table 29-1: Minimum Required Documents and Records**

Document/Record	Purpose	Completion/ Update Frequency	Format/ Storage Location/ Archive Requirements
Site Manager Log			
Quality Control (QC) Seed Plan			
QC Firewall Plan			
Daily QC Reports			

**Table 29-1: Minimum Required Documents and Records**

Document/Record	Purpose	Completion/ Update Frequency	Format/ Storage Location/ Archive Requirements
Weekly Geophysical QC Report			
Team Leader Log(s)			
Field Change Request Form			
Root Cause Analysis			
Photograph Log			
Production Area QC Seeding Report			
Surface Sweep Technical Memorandum			
Land Survey/Control Point Data Report			
Instrument Verification Strip (IVS) Technical Memorandum			
SOP Checklists			
Seed Tracking Log			
Data Usability Assessments (detection survey, cued survey and final DUA)			
Target Selection Technical Memorandum			
Final Ranked Dig List			
Reacquisition Results			

**Table 29-1: Minimum Required Documents and Records**

Document/Record	Purpose	Completion/ Update Frequency	Format/ Storage Location/ Archive Requirements
Intrusive Investigation Results			
Anomaly Resolution Results			
Digital Geophysical Mapping (DGM) Data Deliverable			
DGM QC Deliverable			
Supporting Classification Images			

**QAPP Worksheet #31, 32 & 33: Assessments and Corrective Action  
(UFP-QAPP Manual Sections 4.1.1 and 4.1.2)**

This worksheet is used to document responsibilities and procedures for conducting project assessments, documenting assessments, responding to assessment findings, and implementing corrective action. Appropriately scheduled assessments during each group of related project activities allow management to identify problems while the activities are being implemented, thereby allowing processes to be corrected before they have a negative impact on the achievement of DQOs and MPCs. This worksheet should reference assessment checklists and include them in an appendix to the QAPP.

For this project, related activities are grouped as follows:

1. Site preparation (DFW 1-2)
2. Detection survey (DFW 3-5)
3. Cued survey (DFW 6-10)
4. Intrusive investigation (DFW 11-13)

[Example] For each group of related activities, assessment activities will occur during the following phases:

Preparatory Phase: Comprises the planning and design process leading up to field activities. The UXOQCS will perform a Preparatory Phase assessment before beginning each group of activities. The purpose of this assessment is to review applicable specifications and plans to verify that the necessary resources, conditions, and controls are in place and comply with specifications before field work begins.

Initial Phase: Occurs at the startup of field activities. The purpose of this phase is to check preliminary work for compliance with specifications, check for omissions, and resolve differences of interpretation.

Follow-up Phase: Covers the routine, day-to-day activities at the site. One or more follow-up assessments will be conducted during each related group of activities, depending on the duration of field activities, and the nature of any assessment findings.

**Table 31-1: Assessment Schedule**

Assessment Type	Responsible Party	Schedule/Frequency	Assessment Deliverable	Deliverable due date
Site Preparation Preparatory phase			Preparatory Phase Inspection Checklist	
Site Preparation Initial phase			Initial Phase Inspection Checklist	
Site Preparation Follow-up phase			Follow-up Phase Inspection Checklist	
Detection Survey Preparatory phase				
Detection Survey Initial phase				
Detection Survey Follow-up phase				
Cued Survey Preparatory phase				
Cued Survey Initial phase				
Cued Survey Follow-up phase				
Intrusive Investigation Preparatory phase				
Intrusive Investigation Initial phase				
Intrusive Investigation Follow-up phase				

**Table 31-2: Assessment Response and Corrective Action**

<b>Assessment Type</b>	<b>Responsibility for responding to assessment findings</b>	<b>Assessment Response Documentation</b>	<b>Timeframe for Response</b>	<b>Responsibility for Implementing Corrective Action</b>	<b>Responsible for monitoring Corrective Action implementation</b>
Site Preparation All phases					
Detection Survey All phases					
Cued Survey All phases					
Intrusive Investigation All phases					

**QAPP Worksheet #34: Data Verification, Validation, and Usability Inputs  
 (UFP-QAPP Manual Section 5.2.1 and Table 9)**

This worksheet is used to list the inputs that will be used during data verification, validation, and usability assessment. Inputs include all requirements documents (e.g. contracts, SOPs, planning documents), field records (both hard-copy and electronic), and interim and final reports. Data verification is a completeness check that all specified activities involved in data collection and processing have been completed and documented and that the necessary records (objective evidence) are available to proceed to data validation. Data validation is a detailed evaluation of data for conformance to stated requirements, e.g., those contained in the contract, SOPs and Worksheet #22. The data usability assessment is an evaluation of the data set making up a delivery unit, to determine whether the data support their intended uses. It is an evaluation of conformance to the MPCs presented in Worksheet #12. Examples of requirements documents as well as records subject to verification and validation are listed below in blue text.

**Requirements/Specifications:**

Contract No. \_\_\_\_\_  
 Quality Assurance Project Plan, (Title)  
 SOPs (see Appendix \_\_)

**Table 34-1 Data Verification, Validation and Usability Inputs**

Description	Verification (completeness)	Validation (conformance to specifications)	Usability (achievement of DQOs and MPCs)
QC Seeding Records	X	X	
Surface Sweep Seeding QC Checklist	X	X	
Production Area Seeding QC Checklist	X	X	
Field logbooks	X		
Photographs	X		
Instrument Assembly Checklist (Detection Survey)	X	X	
Sensor Function Test Results (Detection Survey)	X	X	
IVS Construction Details	X	X	
IVS Checklists (Detection Survey)	X		
Detection Survey Data Collection QC Checklist	X	X	

**Table 34-1 Data Verification, Validation and Usability Inputs**

<b>Description</b>	<b>Verification (completeness)</b>	<b>Validation (conformance to specifications)</b>	<b>Usability (achievement of DQOs and MPCs)</b>
Detection Survey Data Processing QC Checklist	X	X	
Digital Field Notes	X		
Daily QC Reports	X		
Instrument Assembly Checklist (Cued Survey)	X	X	
Sensor Function Test Results (Cued Survey)	X	X	
IVS Checklists (Cued Survey)	X	X	
Cued Data Collection QC Checklist	X	X	
Cued Data Processing QC Checklist	X	X	
Raw data files (EMI, GPS, and IMU)	X	X	
Converted data files	X	X	
Data Processing Log (Detection Survey)	X		
Digital Field Notes	X		
Mapped Detection Metric Data	X	X	
Target Anomaly List	X	X	
Final Data Archive (for each delivered area subset)	X	X	
Cued Measurement Data (Target Measurement Data, Background Measurement Data, and Target Features Database)	X	X	
Classification Images (pdf files)			
Production Area Seed Report			X
IVS Memorandum (Detection Survey)			X



**Table 34-1 Data Verification, Validation and Usability Inputs**

Description	Verification (completeness)	Validation (conformance to specifications)	Usability (achievement of DQOs and MPCs)
Detection Survey Data Processing Letter Report (data validation report)			X
IVS Memorandum (Cued Survey)			X
Site-specific library			X
Cued Survey QC Report (data validation report)			X
Prioritized Target List			X
Target Classification Report			X
Revised Validation Plan			X
Final Validation Plan			X

**QAPP Worksheet #35: Data Verification and Validation Procedures  
 (UFP-QAPP Manual Sections 5.2.2)**

This worksheet documents procedures that will be used to verify and validate project data. Data verification is a completeness check to confirm that all required activities were conducted, all specified records are present, and the contents of the records are complete. Data validation is the evaluation of conformance to stated requirements. [Some examples are provided in blue text; however, this is not a comprehensive list.]

**Table 35-1: Data Verification and Validation Procedures**

Activity and Records Reviewed	Requirements/ Specifications	Process Description/Frequency	Responsible Person	Documentation
Field logbook/electronic files	QAPP	All information is complete for each day of field activities. Any changes/exceptions are documented and have been reported in accordance with requirements. Required signatures are present.	Project Geophysicist	Daily QC Report
Instrument Assembly	SOP <u>X</u>	Instrument Assembly has completed according to SOP <u>X</u> . MQOs have been achieved, with any exceptions noted. If appropriate, corrective actions have been completed. Signatures and dates are present.	Project Geophysicist	SOP <u>X</u> Checklist Daily QC Report
Initial IVS Survey	SOP <u>X</u>	Initial IVS Survey has been conducted according to SOP <u>X</u> . Checklist <u>X</u> has been completed. All specifications have been achieved, or exceptions noted. If appropriate, corrective actions have been completed. Signatures and dates are present.	Project Geophysicist	SOP <u>X</u> Checklist Daily QC Report

### **QAPP Worksheet #36: Advanced Geophysical Classification Validation**

This worksheet documents procedures that will be used to validate the overall anomaly detection and classification approach as it is implemented at a specific site. The purpose of classification validation is to provide added confidence in the ability of the sample design to 1) select anomalies meeting the project-specific detection threshold for further investigation, and 2) correctly classify anomalies to distinguish between TOI and non-TOI. This worksheet can either include the draft Verification and Validation Plan, or reference it and include it in an appendix. The draft Verification and Validation Plan is finalized following cued data processing.

The validation approach involves testing the thresholds for both anomaly detection and anomaly classification in two ways: 1) Placing “blind” validation and QC seeds at the site before the project begins, to confirm that the seeds can be detected and correctly classified; 2) Conducting “threshold verification”, i.e., the excavation of additional targets (non-TOI) just beyond the thresholds used for detection and classification, to verify selection of the appropriate threshold; , and 3) Conducting classification validation, which involves a qualitative evaluation of how well the classification process predicted physical properties of the non-TOI. Classification validation is conducted at the end of the project, following the intrusive investigation. The results of classification validation will be considered during the data usability assessment described in Worksheet #37.

#### **Classification validation approach:**

[Example] The draft Verification and Validation Plan is included in Appendix \_ to this QAPP. The draft Verification and Validation Plan describes how each of the decision-making thresholds for detection and classification will be tested and identifies how anomalies will be selected for the threshold verification and classification validation. It addresses the contractor’s QC seeding plan, threshold verification, and classification validation. [Note: The placement of validation seeds is addressed in the lead organization’s Quality Assurance Surveillance Plan.] The number, type, and placement of QC seeds depend on project-specific DQOs. The final number and distribution of threshold verification targets and classification validation targets depends on the DQOs, as well as actual performance in the field against established MPCs. For that reason, the validation approach evolves as the project is implemented.

**QAPP Worksheet #37: Data Usability Assessment (DUA)  
(UFP-QAPP Manual Section 5.2.3 including Table 12)**

This worksheet documents procedures that will be used to perform the DUA. The DUA is performed by key members of the project team (defined during the SPP) at the conclusion of data collection activities for each phase of investigation (i.e., the detection survey, the cued survey, and the intrusive investigation) before proceeding to the next phase, as shown on Figure 17-1. [Note: one or more survey units may be grouped into a delivery unit for the purpose of conducting the DUA. Since payment may be tied to the completion of a delivery unit, the establishment of delivery units usually will be negotiated during contracting.] The DUA uses the outputs from data verification and data validation, including the Final Classification Validation Report).

The different phases of the DUA involves a qualitative and quantitative evaluation of environmental data for the detection phase, cued phase, and intrusive investigation, to determine if the project data are of the right type, quality, and quantity to support the MPCs and DQOs specific to that phase of the investigation. It involves a retrospective review of the systematic planning process to evaluate whether underlying assumptions are supported, sources of uncertainty have been managed appropriately, data are representative of the population of interest, and the results can be used as intended with an acceptable level of confidence.

Identify personnel (organization and position/title) responsible for participating in the data usability assessment: [Note: the same personnel should participate in all phases of the DUA.

DoD RPM

Project Manager

Project QA Manager

Project Geophysicist

QC Geophysicist

Field Geophysicist (Lead)

Identify documents used as input to each phase of the data usability assessment:

Quality Assurance Project Plan

Contract Specifications

Quality Assurance Surveillance Plan

Final Verification and Validation Plan

Weekly QC Reports

Assessment Reports Corrective Action Reports

Production Area Seed Report

IVS Memoranda

Detection Survey Data Validation Report

Site-Specific Library

Cued Survey Data Validation Report  
 Prioritized Target “Dig” List  
 Target Classification Report  
 Classification Validation Report

Describe how the usability assessment will be documented: The detection and cued survey DUAs will be documented in a detection survey DUA report and cued survey DUA report, respectively. [The final data usability assessment report will be included as an appendix to the Final Report.](#)

<p><b>Step 1</b></p>	<p><b>Review the project’s objectives and sampling design</b></p> <p><i>Review the data quality objectives. Are underlying assumptions valid? Were the project boundaries appropriate? Review the sampling design as implemented for consistency with stated objectives. Were sources of uncertainty accounted for and appropriately managed? Summarize any deviations from the planned sample design.</i></p>
<p><b>Step 2</b></p>	<p><b>Review the data verification/validation outputs and evaluate conformance to MPCs documented on Worksheet #12</b></p> <p><i>Review the site-specific project library for completeness. Review available QA/QC reports, including weekly QC reports, assessment reports, corrective action reports, and the data verification/validation reports. Evaluate the implications of unacceptable QC results. Evaluate conformance to MPCs documented on Worksheet #12. Summarize the impacts of non-conformances on data usability.</i></p>
<p><b>Step 3</b></p>	<p><b>Document data usability, update the CSM, and draw conclusions</b></p> <p><i>Determine if the data can be used as intended, considering implications of deviations and corrective actions. Assess the performance of the sampling design and Identify any limitations on data use. For the detection survey and cued survey DUAs, determine whether the data are suitable for proceeding to the next phase. Update the conceptual site model and document conclusions.</i></p>
<p><b>Step 4</b></p>	<p><b>Document lessons learned and make recommendations</b></p> <p><i>Summarize lessons learned and make recommendations for changes to DQOs or the sampling design for future delivery units at the site, or future investigations. Prepare the data usability summary report.</i></p>

# Appendix A

## Example Standard Operating Procedures

## Appendix A Table of Contents

---

STANDARD OPERATING PROCEDURE 1M: Assemble the MetalMapper System and Verify Correct Operation .....	75
SOP 1M: Attachment 1 Preparatory MetalMapper Assembly QC Checklist.....	81
STANDARD OPERATING PROCEDURE 1T: Assemble the TEMTADS 2x2 System and Verify Correct Operation .....	82
SOP 1T: Attachment 1 Preparatory TEMTADS Assembly QC Checklist.....	89
STANDARD OPERATING PROCEDURE 2: Test Sensor and System at the Instrument Verification Strip (IVS).....	84
SOP 2 Attachment 1 Preparatory IVS Construction QC Checklist.....	98
SOP 2: Attachment 2 Initial IVS QC Checklist.....	99
SOP 2: Attachment 3 Follow-on IVS QC Checklist.....	100
STANDARD OPERATING PROCEDURE 3: Production Area Seeding .....	101
SOP 3: Attachment 1 Preparatory Production Area Seeding QC Checklist.....	105
STANDARD OPERATING PROCEDURE 4M: Perform Dynamic Surveys with MetalMapper .....	106
SOP 4M: Attachment 1 Dynamic MetalMapper Data Collection QC Checklist.....	110
STANDARD OPERATING PROCEDURE 4T: Perform Dynamic Surveys with TEMTADS 2x2.....	111
SOP 4T: Attachment 1 Dynamic TEMTADS Data Collection QC Checklist.....	115
STANDARD OPERATING PROCEDURE 5M: Process Dynamic Survey Data - MetalMapper .....	116
SOP 5M: Attachment 1 Dynamic MetalMapper Data Processing QC Checklist.....	122
STANDARD OPERATING PROCEDURE 5T: Process Dynamic Survey Data - TEMTADS 2x2.....	123
SOP 5T: Attachment 1 Dynamic TEMTADS Data Processing QC Checklist.....	129
STANDARD OPERATING PROCEDURE 6: Collect Static Background Measurements .....	130
SOP 6: Attachment 1 Preparatory Background Collection QC Checklist .....	135
SOP 6: Attachment 2 Initial Background Data Collection QC Checklist .....	136
SOP 6: Attachment 3 Follow-on Background Data Collection QC Checklist .....	137
STANDARD OPERATING PROCEDURE 7: Collect Cued Target Measurements.....	138
SOP 7: Attachment 1 Cued Geophysical Data Collection Follow-on QC Checklist.....	142
STANDARD OPERATING PROCEDURE 8: Process Cued MetalMapper or TEMTADS Data .....	143
Attachment 1 Cued Geophysical Data Processing QC Checklist.....	149
STANDARD OPERATING PROCEDURE 9: Verify Recovered Objects Are Compatible With Predictions .....	150
SOP 9: Attachment 1 Follow-on QC Checklist for Recovered Item Verification .....	153
STANDARD OPERATING PROCEDURE 10: Validate Classification Process.....	154
SOP 10: Attachment 1 Follow-on QC Checklist for Validation.....	156

## STANDARD OPERATING PROCEDURE 1M

### Assemble the MetalMapper System and Verify Correct Operation

---

#### 1. Purpose and Scope

The purpose of this Standard Operating procedure (SOP) is to identify the methods to be employed when assembling the MetalMapper sensor system and verifying that all components are correctly assembled, operating normally, and capable of acquiring data of sufficient quality.

#### 2. Personnel, Equipment and Materials

This section describes the personnel, equipment and materials required to implement this SOP.

The following individuals will be involved in the assembly and verification of the MetalMapper:

- Project Geophysicist
- QC Geophysicist
- Field Team Leader
- Data Processor

The qualifications of the personnel implementing this SOP are documented in the QAPP Worksheet #4, 7 & 8.

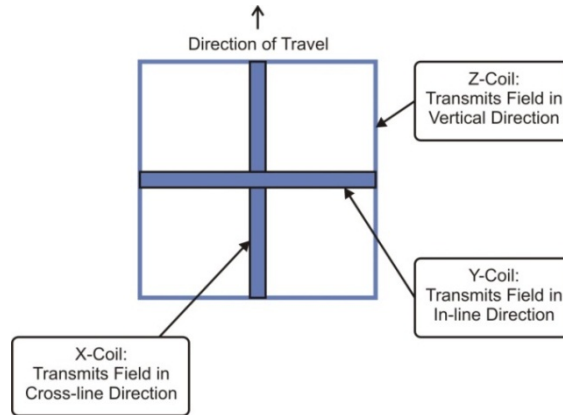
The following is a list of required equipment and materials:

- Geometrics MetalMapper sensor coupled with a real-time kinematic Global Positioning System (RTK GPS) and Inertial Measurement Unit (IMU) for orientation measurements
- transport vehicle (skid steer, tractor, extended reach forklift) used to move the MetalMapper during data collection
- a schedule 80 small Industry Standard Object (small ISO80) for operational testing
- digital camera or cell phone. (Note, personnel should not have cell phones when operating the MetalMapper)

#### 3. Procedures and Guidelines

The Geometrics MetalMapper is an advanced electromagnetic induction sensor designed for the detection and classification of buried metal objects. The sensor consists of three orthogonal 1-m x 1-m transmit coils for target illumination and seven, three-axis receive cubes. It measures the decay curve up to 8-ms after the transmitters are turned off for each of the 21 receive channels. The orientation of the three transmit coils is shown in Figure 1.

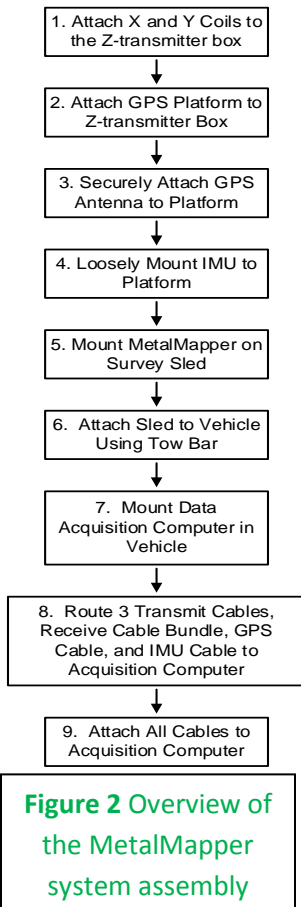




**Figure 1.** Orientation of the three MetalMapper transmit coils

Positioning of the MetalMapper is accomplished using an RTK GPS. The MetalMapper orientation is measured using a six-degree-of-freedom inertial measurement unit (IMU). For proper functioning it is important to verify that the IMU has been mounted to the MetalMapper in the correct orientation.

### 3.1. Assemble the MetalMapper



All assembly operations are described in the MetalMapper manual as published by Geometrics (see [http://www.geometrics.com/files/metalmapper\\_manual\\_beta1.pdf](http://www.geometrics.com/files/metalmapper_manual_beta1.pdf)) and the detailed instructions contained there should be followed precisely. Figure 2 shows a schematic overview of the assembly steps which are briefly described below:

1. Using the bolts and brackets provided, attach the X transmitter coil then the Y transmitter coil to the Z-transmitter box.
2. Attach the GPS platform legs to the Z-transmitter box and then the GPS platform to the legs.
3. Securely attach the GPS antenna to the platform.
4. Loosely attach the IMU to the platform. The attachment will be secured after correct IMU orientation is verified.
5. Mount the MetalMapper on the survey sled that will be used.
6. Mount one end of the attachment bar to the survey sled and the other end to the vehicle using the hitch mount provided.
7. Mount the data acquisition computer in the vehicle so that it can be easily accessed by the operator. Mount the display screen where it can be easily seen by the operator during normal vehicle operations. Do not obscure the operator’s view of the sensor sled with the computer or screen.
8. Route all cables (three transmit cables, the receive cable bundle, and the cables for the GPS and IMU) along the attachment bar to the acquisition computer. Secure the cables to the bar in several places.

9. Attach all cables to the marked connectors in the acquisition computer.

### 3.2. Verify Assembly

In order for the standard data analysis routines to successfully handle MetalMapper data, you must verify that the transmit coils have been assembled in the correct orientation and the IMU has been installed correctly.

#### 3.2.1. Orientation of the Transmit Coils

The correct orientation of the transmit coils and their polarities are shown in Figure 3. Visually verify that the assembled sensor matches this diagram.

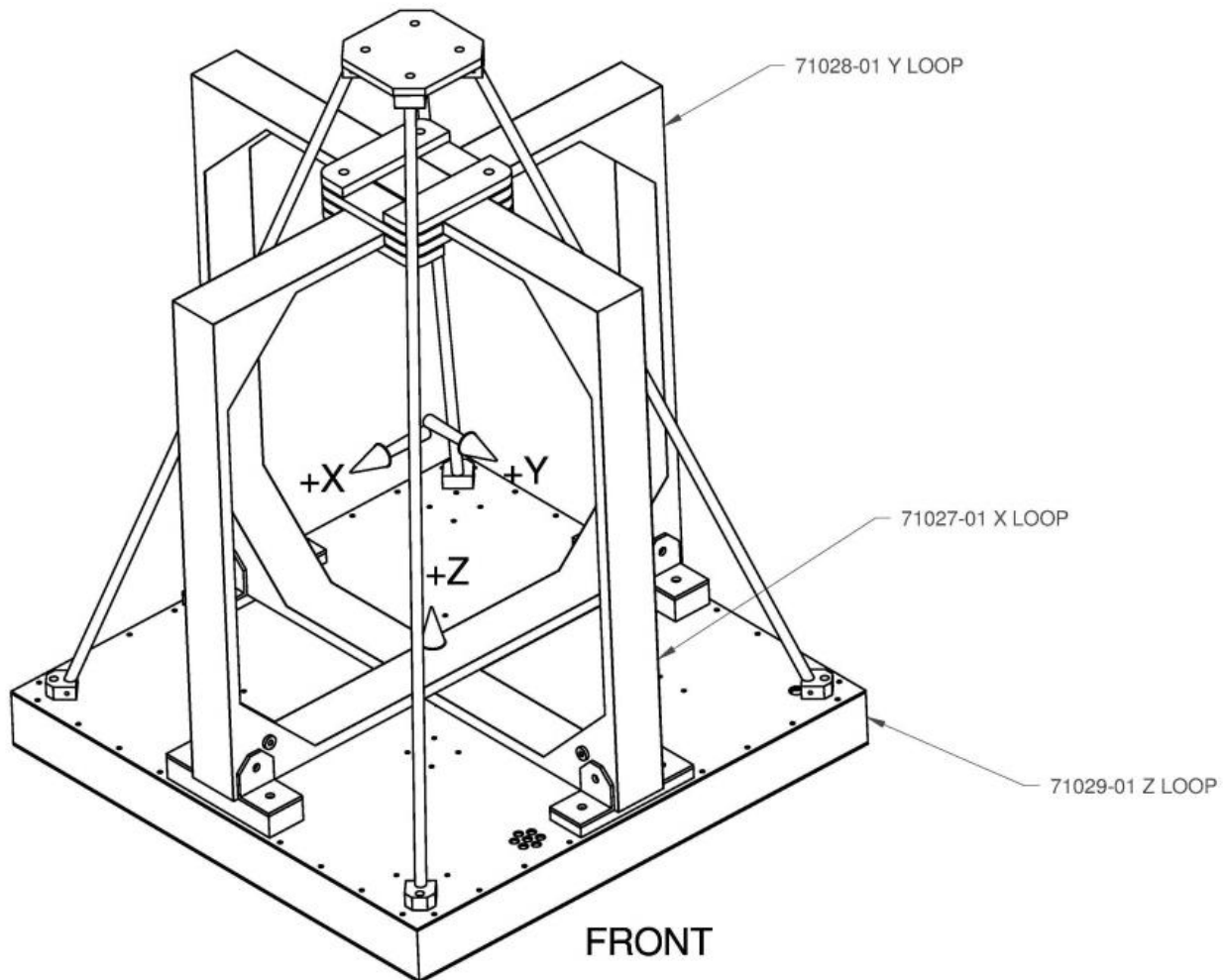


Figure 3. Correct orientations and polarities of the three MetalMapper transmit coils

### 3.2.2. Orientation of the IMU

The procedure to verify the correct orientation of the IMU is shown in Figure 4 and instructions for this test follow:

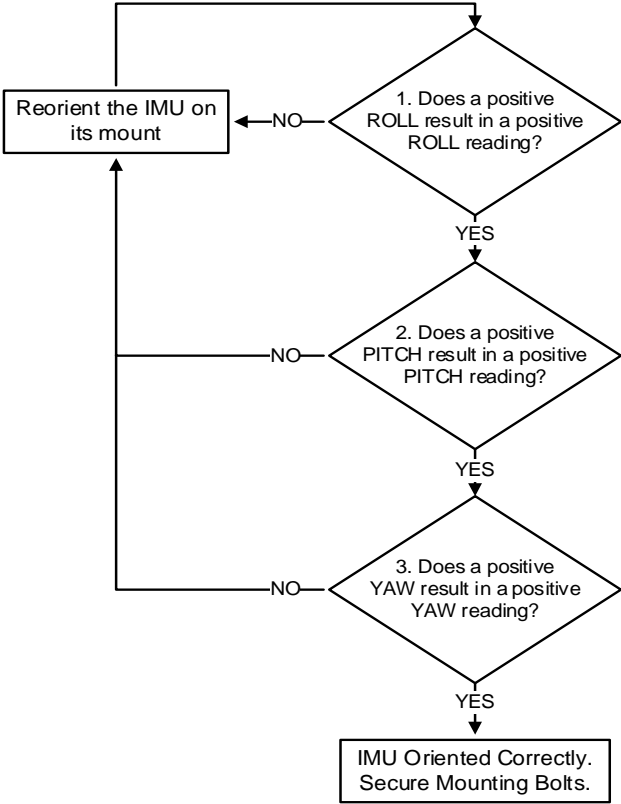


Figure 4. Procedure for verifying IMU Orientation

1. Facing the direction of travel, rotate the IMU around the along-track axis to produce a positive ROLL as shown in Figure 5. Verify that the data acquisition system records a positive ROLL. If it does not, reorient the IMU on its mount and test again.

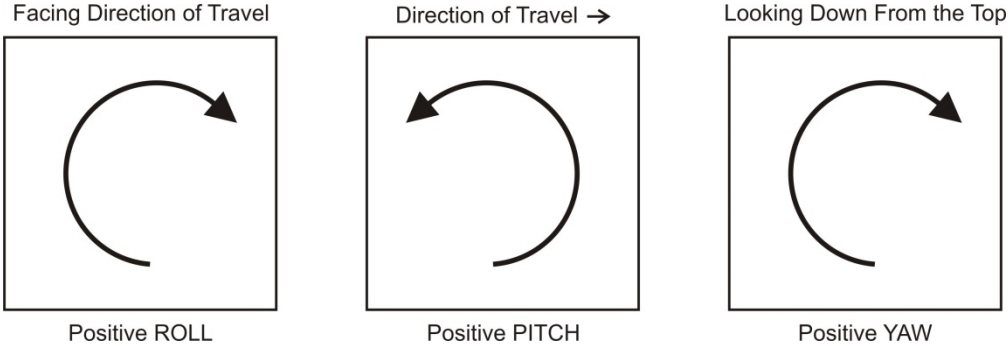


Figure 5. Positive ROLL, PITCH, and YAW rotations of the IMU

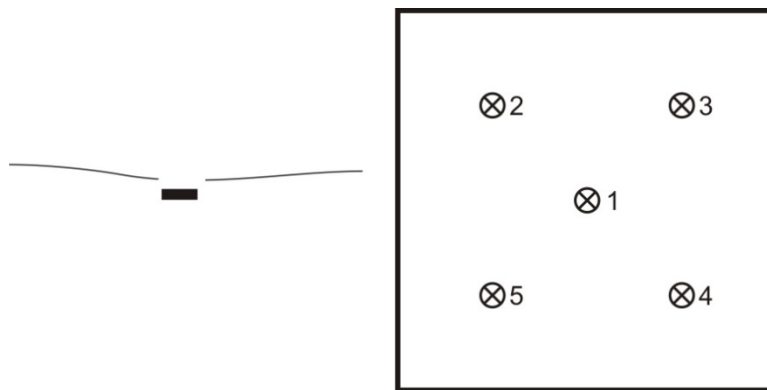
2. Standing on the side of the sensor with the direction of travel to your right, rotate the IMU around the cross-track axis to produce a positive PITCH as shown in Figure 5. Verify that the data acquisition system records a positive PITCH. If it does not, reorient the IMU on its mount and return to step 1.
3. Looking down on the sensor from above, rotate the IMU around the vertical axis to produce a positive YAW as shown in Figure 5. Verify that the data acquisition system records a positive YAW. If it does not, reorient the IMU on its mount and return to step 1.

### 3.2.3. Operation of the GPS

Turn on the GPS receiver, allow it time to lock onto a position, and verify that GPS readings are being received at the data acquisition computer.

### 3.2.4. MetalMapper Function Test

Dig, or find, a small depression in the ground in a clear area as shown on the left side of Figure 6. Place a small ISO80 in the depression oriented horizontally. Center the MetalMapper over the depression so that the ISO is under measurement position 1.



**Figure 6.** Small ISO80 placed horizontally in a shallow depression (left) and the five measurement locations under the MetalMapper (right)

Collect a cued measurement with the MetalMapper. Verify that the transmit current is within the expected range. Position the MetalMapper so the ISO is under measurement positions 2 through 5 collecting cued data in each position. Invert each of the five data sets and verify that the resulting polarizability decays match the library values for a small ISO80 with a match metric of 0.95 or greater.

### 3.2.5. Photograph the Sensor

Using a cell phone or other pocket camera, photograph the installed sensor. Verify that the photograph(s) depict the orientation of the MetalMapper relative to the vehicle and shows the locations of the GPS and IMU sensors.

## 4. Data Management

The following sections describe the data that is needed to perform this SOP and the resulting data.

### 4.1. Input Data Required

Input data consists of the MetalMapper manual as published by Geometrics.

### 4.2. Output Data

The five test measurements over the ISO80 described in Section 3.2.4 will be saved in the project database along with the inversion results and library match metric for each of the measurements. Also, the QC checklist in Attachment 1 of this SOP will be completed, signed, and filed with the assembly photograph as proof of correct assembly.

## 5. Quality Control

As this definable feature of work is accomplished only during the preparatory phase, only preparatory QC checks will be performed. QC consists of performing the inspections on the Preparatory Phase Quality Control Checklist that is included as Attachment 1 to this SOP. This checklist will be completed by the Field or Project Geophysicist and will be observed by the QC geophysicist who will document the implementation of this SOP in the Geophysics Daily QC Report.

The measurement quality objectives (MQOs) for this task are presented in Worksheet #22 of the project-specific QAPP. The MetalMapper will not be tested on the Instrument Verification Strip (IVS) (SOP 2) until the MQOs are documented as being met as described below.

## 6. Reporting

Achievement of the Sensor Assembly MQOs (see the MQOs in Worksheet #22) will be documented by the Field or Project Geophysicist by completion of the Preparatory QC Checklist in Attachment 1 to this SOP and will be verified by the QC Geophysicist in the Geophysics Daily QC Report.

The delivered data package for the assembled and tested MetalMapper will include:

- a brief description of the assembly and test process along with the photograph(s) taken in Section 3.3 will be included in the IVS letter report.
- the completed Preparatory QC Checklist signed by the Project, Field Geophysicists verifying the assembly and orientation tests described above.
- the inversion results from the five measurements over the ISO80 overlain over the library polarizabilities for the small ISO80.
- the verification in the Geophysics Daily QC Report.

## SOP 1M

### Attachment 1 Preparatory MetalMapper Assembly QC Checklist

This checklist is to be completed by the Project or Field Geophysicist and checked by the QC Geophysicist during assembly and initial testing of the MetalMapper.

QC Step	QC Process and Guidance Reference	Yes/ No	Initial of Field or Project Geophysicist
1. Qualifications	Have the qualifications of the Project and Field Geophysicists and the Data Processor listed in QAPP Worksheet #4, 7 & 8 been verified?		
2. Assembly	Is the MetalMapper assembled in accordance with the published instructions and in the sequence i/a/w this SOP?		
3. Assembly: Transmit coil verification	Is the orientation of the transmit coils verified to be in the correct orientation i/a/w this SOP?		
4. Testing: IMU orientation verification	Has the procedure and tests for verification of the IMU orientation been completed i/a/w this SOP?		
5. Testing: GPS	Was the GPS warmed up and allowed time to lock onto position i/a/w this SOP?		
6. Photograph the installation	Was a photograph showing the orientation of the MetalMapper relative to the vehicle and the placement of the GPS and IMU taken?		
7. Testing: ISO80 placement	Was an ISO80 used for testing and was it placed i/a/w this SOP?		
8. Testing: MetalMapper functioning	Was the MetalMapper tested over the ISO80 in all five locations i/a/w this SOP? Record the library match metric for the five inversions below: 1. _____ 2. _____ 3. _____ 4. _____ 5. _____		
9. MQO Documentation	Have the appropriate MQOs from Worksheet #22 been achieved?		

Project or Field Geophysicist: \_\_\_\_\_ Date: \_\_\_\_\_

Data Processor: \_\_\_\_\_ Date: \_\_\_\_\_

QC Geophysicist: \_\_\_\_\_ Date: \_\_\_\_\_

## STANDARD OPERATING PROCEDURE 1T

### Assemble the TEMTADS 2x2 System and Verify Correct Operation

---

#### 1. Purpose and Scope

The purpose of this Standard Operating procedure (SOP) is to identify the methods to be employed when assembling the TEMTADS 2x2 sensor system for dynamic collection and verifying that all components are correctly assembled, operating normally, and are capable of acquiring data of sufficient quality.

#### 2. Personnel, Equipment and Materials

This section describes the personnel, equipment and materials required to implement this SOP.

The following individuals will be involved in the assembly and verification of the TEMTADS:

- Project Geophysicist
- Field Team Leader
- Quality Control (QC) Geophysicist
- Data Processor

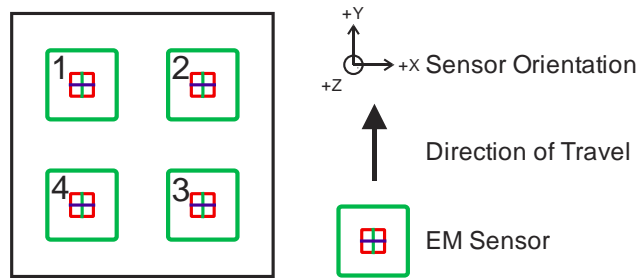
The qualifications of the personnel implementing this SOP are documented in the QAPP Worksheet #4, 7 & 8.

The following is a list of required equipment and materials:

- TEMTADS 2x2 sensor coupled with a real-time kinematic Global Positioning System (RTK GPS) and Inertial Measurement Unit (IMU) for orientation measurements
- a schedule 80 small Industry Standard Object (small ISO80) in the Delrin mounting ring for sensor function testing
- a digital camera or cell phone. (Note, personnel should not have cell phones when operating the TEMTADS)

#### 3. Procedures and Guidelines

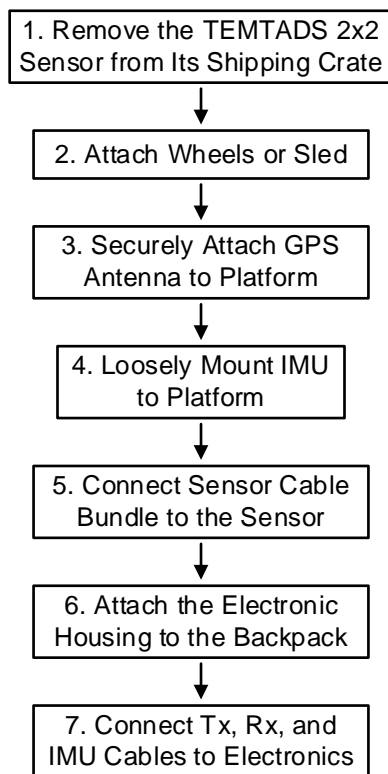
The TEMTADS 2x2 is an advanced electromagnetic induction sensor designed for the detection and classification of buried metal objects. The sensor consists of four sensor elements arranged on 40-centimeter (cm) centers in a 2x2 array. Each sensor element consists of a 35-cm square transmit coil for target illumination with an 8-cm three-axis receive cube centered in the transmit coil. The transmitters are energized in sequence and the decay curve is recorded up to 25 milliseconds after the transmitters are turned off for each of the 12 (4 cubes with 3 axes each) receive channels. A schematic of the sensor coil configuration is shown on Figure 1.



**Figure 1.** Orientation of the Four TEMTADS 2x2 Sensor Elements (topview)

Positioning of the TEMTADS 2x2 is accomplished using an RTK GPS. The TEMTADS 2x2 orientation is measured using a six-degree-of-freedom IMU. For proper functioning it is important to verify that the IMU has been mounted to the TEMTADS 2x2 in the correct orientation.

### 3.1. Assemble the TEMTADS 2x2



**Figure 2.** Overview of the TEMTADS Assembly Process

All assembly operations are described in the TEMTADS 2x2 unpacking instructions and user guide available from the Naval Research Laboratory (NRL) and the detailed instructions contained there should be followed precisely. Figure 2 shows a schematic overview of the assembly steps which are briefly described below:

1. Remove the sensor assembly from the packing crate following the instructions in the unpacking guide.
2. Attach the wheels or sled.
3. Securely attach the GPS antenna to the top of the mounting platform. If GPS is not being used, move to Step 4.
4. Set the IMU onto its position below the GPS. The attachment will be secured after correct IMU orientation is verified.
5. Connect the sensor cable bundle to the sensor. This includes the sensor Tx and Rx cables and the cables to the GPS and IMU.
6. Remove the electronic housing from its shipping container and attach it to the backpack.
7. Attach the Tx, Rx, and IMU cables to the electronics box. The GPS cable will be attached after booting the computer.



### 3.2. Turn On and Initialize the Data Acquisition Computers

Following the instructions in Section 5 of the TEMTADS 2x2 User Guide, start the data acquisition system. After the main computer in the electronics housing boots, plug the GPS cable into the electronics. The last step in Section 5 involves observing the IMU output. Leave the system in this state for the next operation.

### 3.3. Verify IMU Orientation

The procedure to verify the correct orientation of the IMU is shown in Figure 3 and instructions for this test follow:

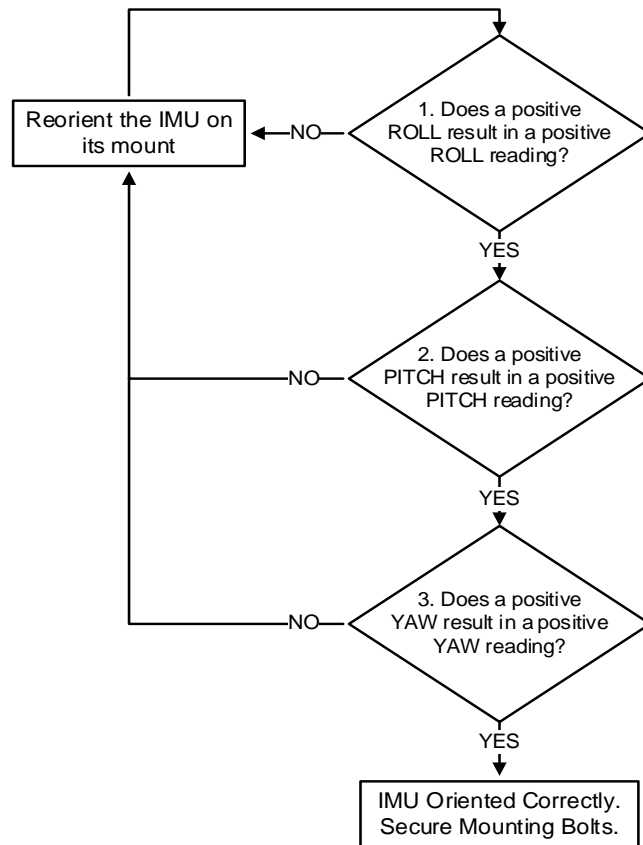


Figure 3. Procedure for Verifying IMU Orientation

1. Facing the direction of travel, rotate the IMU around the long-track axis to produce a positive ROLL as shown in Figure 4. Verify that the data acquisition system records a positive ROLL, Figure 5. If it does not, reorient the IMU on its mount and test again.

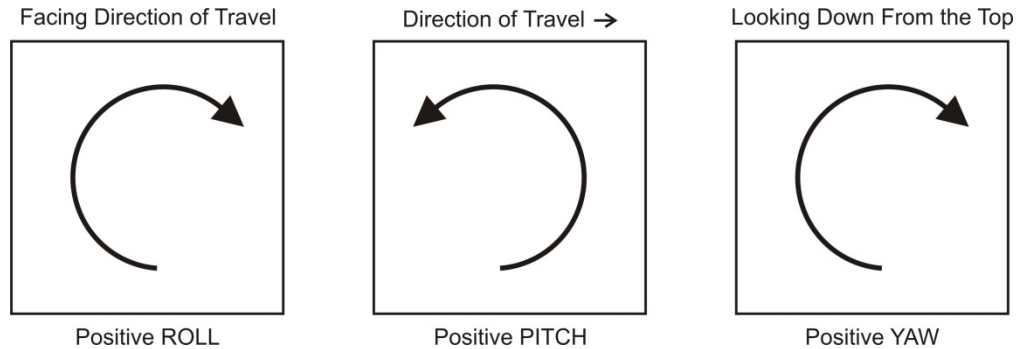


Figure 4. Positive ROLL, PITCH, and YAW Rotations of the IMU

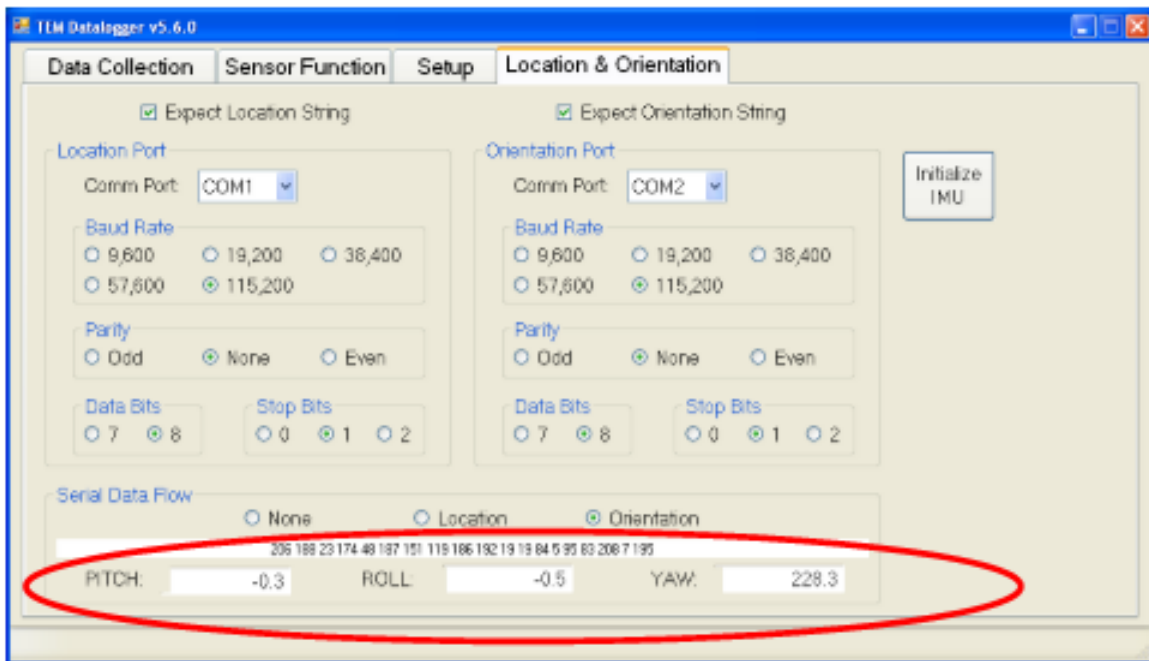


Figure 5. Electronics Box Screen Showing Orientation Inputs

2. Standing on the side of the sensor with the direction of travel to your right, rotate the IMU around the cross-track axis to produce a positive PITCH as shown in Figure 4. Verify that the data acquisition system records a positive PITCH. If it does not, reorient the IMU on its mount and return to step 1.
3. Looking down on the sensor from above, rotate the IMU around the vertical axis to produce a positive YAW as shown in Figure 4. Verify that the data acquisition system records a positive YAW. If it does not, reorient the IMU on its mount and return to step 1.

### 3.4. Photograph the Sensor

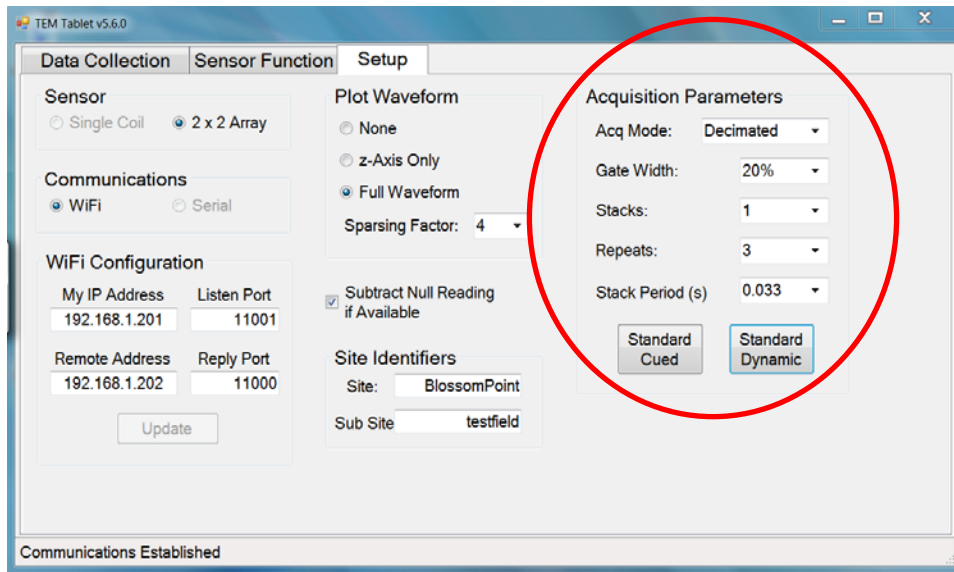
Using a cell phone or other camera, photograph the installed sensor. Verify that the photograph(s) shows the locations and orientations of the GPS and IMU sensors.

### 3.5. Set up the Data Acquisition Parameters

In preparation for the sensor function test, use the [Setup] tab in TEMDataLogger or TEMTablet to set the correct data acquisition parameters for the dynamic survey. The easiest way to accomplish this is to use [Standard Dynamic] or [Standard Cued] button, Figure 6. The standard parameters are listed in Table 1.

**Table 1.** Standard Data Acquisition Parameters

Parameter	Cued Survey	Dynamic Survey
Acq Mode	Decimated	Decimated
Gate Width	5%	20%
Stacks	18	1
Repeats	9	3
Stack Period	0.9	0.033



**Figure 6.** Standard Acquisition Parameters for Dynamic Surveys

### 3.6. Perform a Sensor Function Test

If there is a reference response for the combination of hardware and data acquisition parameters you are using, the [Sensor Function] tab will be available on the data acquisition computer. Access that tab to perform a sensor function test.

1. Position the sensor in a spot known to be clear of buried metal. Often the clear position in the Instrument Verification Strip (IVS) will be the best choice. Collect a background measurement from [Sensor Function] tab of the data acquisition software.
2. Without moving the sensor, mount the ISO80 test item in the hole on the top of the sensor housing.

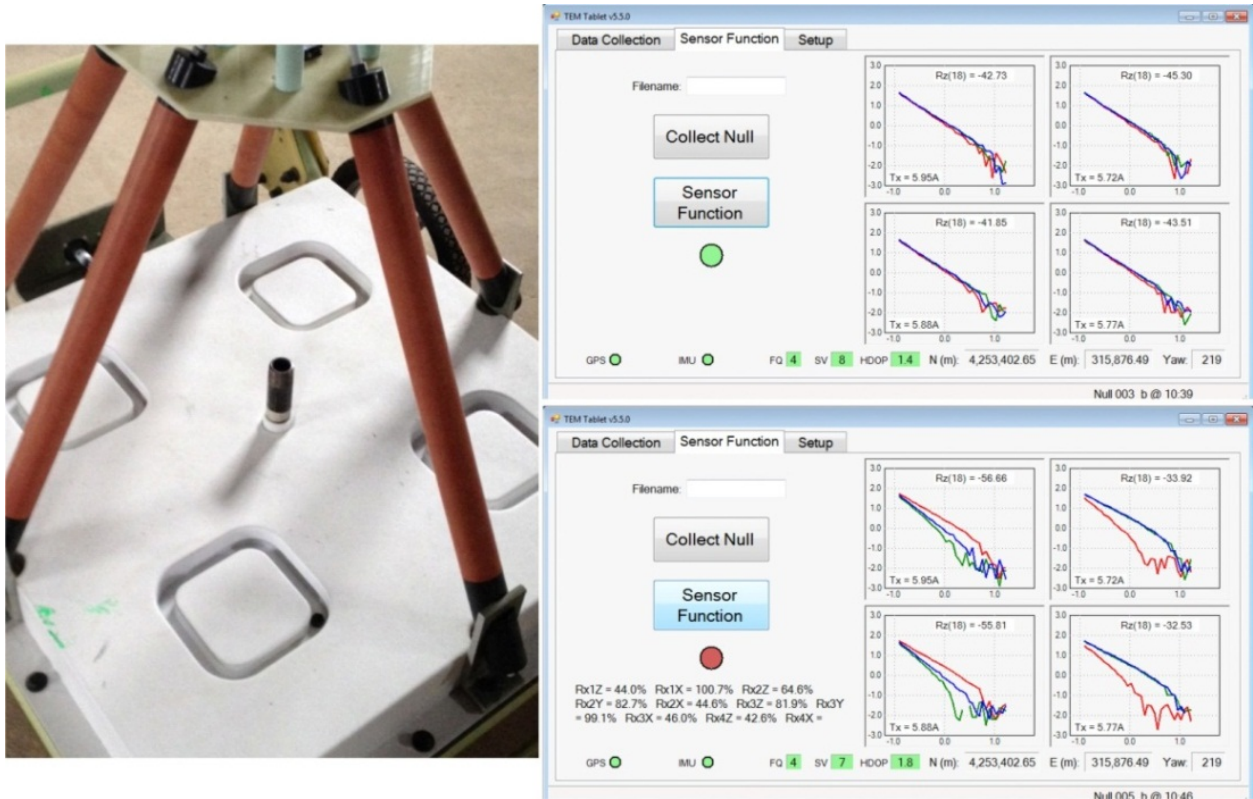


Figure 7, left panel

3. Collect sensor function data. If the results agree with the reference values, a green LED is displayed. If they do not agree, a red LED is displayed and a summary of the incorrect results is displayed.
4. Transfer the background and sensor function data files to the QC Geophysicist for archiving.

## 4. Data Management

The following sections describe the data that is needed to perform this SOP and the resulting data.

### 4.1. Input Data Required

Input data consists of the assembly and operation instructions for the TEMTADS 2x2 contained in the unpacking instructions and user guide available from NRL.

### 4.2. Output Data

The sensor function test described in Section 3.6 will be saved in the project database. Also, the QC checklist in Attachment 1 of this SOP will be completed, signed, and filed with the assembly photograph(s) as proof of correct assembly.

## 5. Quality Control

As this definable feature of work is accomplished only during the preparatory phase, only preparatory QC checks will be performed on this activity. QC consists of performing the inspections on the Preparatory Phase Quality Control Checklist that is included as Attachment 1 to this SOP. This checklist will be completed by the Field or Project Geophysicist and will be reviewed by the QC Geophysicist who will document the implementation of this SOP.

The measurement quality objective (MQO) (QAPP Worksheet #22) for this SOP is verification that the assembly instructions have been followed. The TEMTADS 2x2 will not be tested on the IVS (see SOP 2) until this has been documented as described below.

## 6. Reporting

Achievement of the Sensor Assembly MQO will be documented by the Field or Project Geophysicist by completion of the Preparatory QC Checklist in Attachment 1 to this SOP and will be verified by the QC Geophysicist.

The delivered data package for the assembled and tested TEMTADS will be included in a section of the IVS Letter Report titled "TEMTADS Assembly and Operation Verification" and will include:

- a brief description of the assembly and test process along with the photograph(s) required by Section 3.4 of this SOP.
- the completed Preparatory QC Checklist signed by the Project or Field Geophysicists and checked by the QC Geophysicist verifying the assembly and orientation tests described above.
- the Sensor Function Test result.

## SOP 1T

### Attachment 1 Preparatory TEMTADS Assembly QC Checklist

This checklist is to be completed by the Project or Field Geophysicist and checked by the QC Geophysicist during assembly and initial testing of the TEMTADS.

QC Step	QC Process and Guidance Reference	Yes/No	Initial of Field or Project Geophysicist
1. Assembly	Is the TEMTADS assembled in accordance with the published instructions and in the sequence specified in this SOP?		
2. Testing: IMU orientation verification	Has the procedure and tests for verification of the IMU orientation been completed i/a/w this SOP?		
3. Photograph the installation	Was a photograph showing the placement and orientation of the GPS and IMU taken?		
4. TEMTADS sensor function test	Was the TEMTADS sensor function test performed i/a/w this SOP and were the results saved in the project database?		

Project or Field Geophysicist: \_\_\_\_\_ Date: \_\_\_\_\_

Data Processor: \_\_\_\_\_ Date: \_\_\_\_\_

QC Geophysicist: \_\_\_\_\_ Date: \_\_\_\_\_

## STANDARD OPERATING PROCEDURE 2

### Test Sensor and System at the Instrument Verification Strip (IVS)

---

#### 1. Purpose and Scope

The purpose of this Standard Operating procedure (SOP) is to identify the means and methods to be employed when verifying the operation of an advanced digital geophysical mapping system prior to and during site surveys. The Instrument Verification Strip (IVS) is constructed of a series of buried inert munitions or industry standard objects (ISO). During the IVS process the advanced electromagnetic induction sensor system measures the response of each item in the IVS and these responses are compared to a library of expected responses to ensure and document proper functioning of the system.

#### 2. Personnel, Equipment and Materials

This section describes the personnel, equipment and materials required to implement this SOP.

The following individuals will be involved in verifying correct operation of the MetalMapper system at the IVS:

- Project Geophysicist
- QC Geophysicist
- Field Team Leader
- Data Processor

UXO Personnel will be responsible for overall daily site access and safety aspects of the project, compiling subcontractor health and safety documents, conducting daily safety briefings and performing munitions and explosives of concern (MEC) avoidance, as needed, in the field. Information on the specific qualifications for various UXO personnel support roles can be found in the project Health and Safety Plan.

The qualifications of the personnel implementing this SOP are documented in the QAPP Worksheet #4, 7 & 8.

The following is a list of required equipment and materials:

- Geometrics MetalMapper or TEMTADS sensor coupled with a real-time kinematic Global Positioning System (RTK GPS) and Inertial Measurement Unit (IMU) for orientation measurements
- transport vehicle (skid steer, tractor, extended reach forklift) used to move the MetalMapper during data collection
- inert munitions and/or schedule 80 small ISOs (small ISO80) to construct the IVS
- measuring tape and non-metallic markers (pin flags, stakes, tent pegs, spray paint, etc.) to mark the positions of the test items and the beginning and end of the IVS
- hand tools including shovels, pick axes, breaker bars, etc. to construct the IVS

### **3. Procedures and Guidelines**

#### **3.1. Advanced Digital Geophysical Mapping System**

The advanced digital geophysical mapping (DGM) will be conducted using the Geometrics MetalMapper or TEMTADS both of which have been extensively validated in a series of demonstrations conducted by DoD's Environmental Security Technology Certification Program (ESTCP). Both the MetalMapper and TEMTADS are advanced electromagnetic induction sensors designed for the detection and classification of buried metal objects. The MetalMapper sensor consists of three orthogonal 1-m x 1-m transmit coils for target illumination and seven three-axis receive cubes. Its sampling is electronically programmable and therefore flexible. It measures the decay curve up to 8-ms after the transmitters are turned off for each of the 21 receive channels. The TEMTADS sensor consists of four sensor elements arranged on 40-centimeter (cm) centers in a 2x2 array. Each sensor element consists of a 35-cm square transmit coil for target illumination with an 8-cm three-axis receive cube centered in the transmit coil. The transmitters are energized in sequence and the decay curve is recorded up to 25 milliseconds after the transmitters are turned off for each of the 12 (4 cubes with 3 axes each) receive channels.

Positioning of the sensor will be accomplished using RTK GPS. With adequate satellite visibility, RTK GPS can provide antenna locations with accuracies on the order of 5 cm. The sensor orientation is measured using a six-degree-of-freedom inertial measurement unit (IMU). Combining the sensor orientation and location measurements in this manner typically results in derived target locations within 15 cm of the ground truth.

#### **3.2. Instrument Verification Strip Construction**

Verification of the advanced EMI system is accomplished using an IVS. Multiple IVS locations may be constructed during the project for convenience (for example, to avoid long travel times to reach the IVS on large sites). The construction details and verification procedures described in this document apply to each IVS location.

##### **3.2.1. Location and Configuration of the IVS**

IVS locations will be determined during initial site reconnaissance by the DGM field team. The IVS should be established in an area that is easily accessible, not prone to flooding and other weather-related phenomena, and is determined to be relatively free of subsurface metal objects. The IVS is constructed as one or more survey transects.

##### **3.2.2. IVS Objects**

Seed objects for the IVS can be either actual inert munitions or ISOs. Using inert munitions that match those expected to be found on the site may be preferable as this demonstrates to stakeholders that the system is able to accurately classify the exact MEC of concern. However, using ISOs is the technical equivalent and extraordinary measures to obtain inert munitions are not warranted.



ISOs, if used, should approximate the size of the MEC expected to be found on the site and more than one type of ISO should be used if MEC of various sizes are expected. Small, medium, or large ISOs, singly or in combination, can be selected. Table 1 shows the specifications for the three possible ISO and Figure 1 is a photograph of the three ISO.

**Table 1.** Industry standard objects characterized for use as munitions surrogates

Item	Nominal Pipe Size	Outside Diameter	Length	Part Number <sup>1</sup>	Schedule
Small ISO80	1"	1.315" (33 mm)	4" (102 mm)	4550K226	80
Medium ISO40	2"	2.375" (60 mm)	8" (204 mm)	44615K529	40
Large ISO40	4"	4.500" (115 mm)	12" (306 mm)	44615K137	40

<sup>1</sup> Part number from the McMaster-Carr catalog (<http://www.mcmaster.com/>).



**Figure 1.** Small, medium and large ISO

### 3.2.3. IVS Procedures

Figure 2 illustrates the overall IVS process and the procedures to be followed during the siting, emplacement, and use of the IVS.

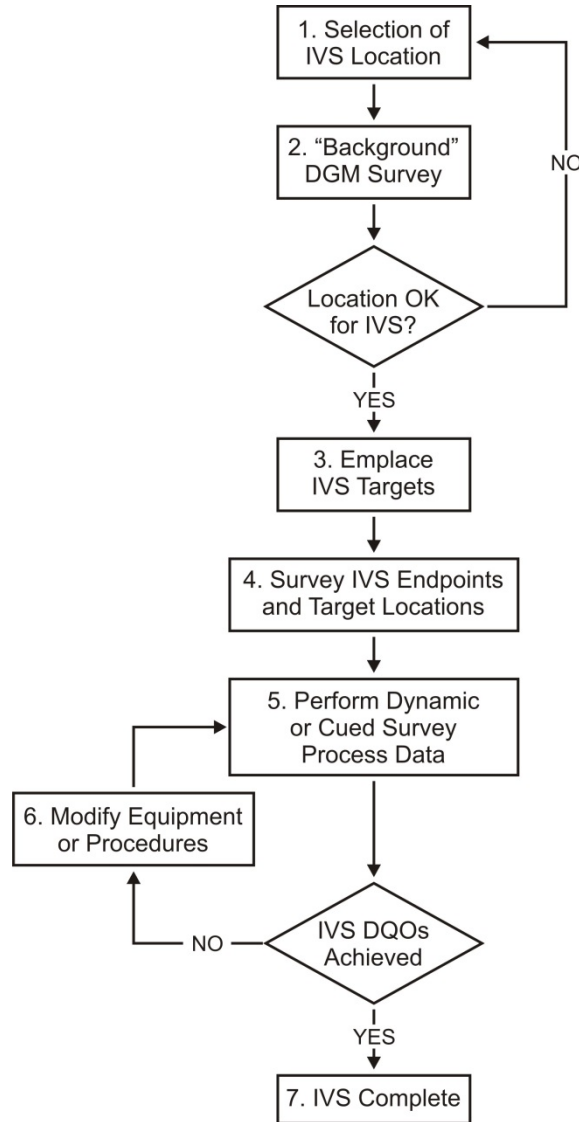
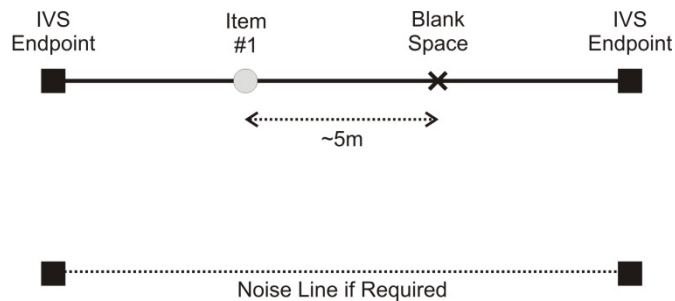


Figure 2: IVS siting, emplacement, and use

1. An IVS location will be selected with preference for the following (although none of the conditions are vital for IVS success):
  - terrain, geology, and vegetation similar to that of a majority of the DGM survey area
  - geophysical noise conditions similar to those expected across the survey area

- large enough site to accommodate all necessary IVS tests and equipment and for adequate spacing (at least 3-m separation and preferably greater) of the ISO items to avoid ambiguities in data evaluation
  - readily accessible to project personnel
  - close proximity to the actual survey site (if not within the site)
2. A background DGM survey will be performed with the MetalMapper or TEMTADS using RTK GPS. The purpose of this step is to document the appropriateness of the location (e.g. few existing anomalies), and will verify that IVS targets are not seeded near existing anomalies. The data from this IVS pre-survey will be processed and provided to the Project, Field and QC Geophysicists for evaluation.
  3. Once the IVS area is deemed suitable for use, (i.e. free of significant subsurface anomalies or containing anomalies that are clearly identified so that they can be avoided during seeding), targets will be buried horizontally at depths below ground surface of approximately 3 and 7 times their diameter. These depths are intended to provide adequate signal to noise ratio for detecting the targets. The generalized diagram of the seeded IVS transect is presented as Figure 3. In this example, only one target is shown. This is the minimum requirement for an IVS. Local custom, stakeholder comfort, or other similar reasons may lead to larger number of items in the IVS. Rarely will more than three or four items be required.



**Figure 3.** Example layout of the IVS

Measurements of the item depths will be to the center of mass of each item. On-site personnel will bury the IVS targets using shovels to dig the holes to the appropriate depths for burial of the seed items in coordination with the QC Geophysicist. UXO personnel will implement MEC avoidance procedures using analog instruments during installation. The background survey data and anomaly avoidance techniques will be reviewed so that transect start and end stakes and the seed items are not placed on top of or near existing anomalies. IVS construction personnel will bury the ISOs and record the following information:

- transect endpoints
- target type
- target emplacement location
- target emplacement depth
- target emplacement orientation (azimuth and inclination)

4. The holes will then be filled with soil and a wooden survey stake or other suitable non-metallic marker will be placed at each buried item location as well as the start and end location of the IVS. The marker will not extend more than 3 inches above the ground surface to prevent interference with the MetalMapper or TEMTADS when passing over them.
5. Prior to collecting production data and each morning before beginning field operations, the MetalMapper or TEMTADS will be used to collect IVS data as follows:

**Cued:**

Cued data will be collected over each of the positions in the IVS including the background location (blank space). The raw .tem files and converted .csv files for each measurement will be passed to the data processor who will perform the following steps:

- a. Examine the cued data from each IVS location and verify that all measured decays are valid.
- b. Verify the data collected over the blank space is suitable for use as a background reading.
  - i. If this is the first measurement on this IVS, verify that all decay amplitudes are below the threshold set in UX-Analyze.
  - ii. Otherwise, verify that all decay amplitudes are within 10% of the mean of those previously measured at this location.
- c. Use the measurement over the blank space to background correct the other data sets and invert the corrected data.
- d. Verify that the resulting polarizabilities match the expected library values with a match statistic of 0.9 or greater.

**Dynamic:**

Dynamic data will be collected along the IVS and noise lines. The raw .tem files and converted .csv files for both measurements will be passed to the data processor who will perform the following steps:

- a. Calculate the RMS variation along the noise line.
    - i. If this is the first noise measurement on this IVS, verify that the site noise is compatible with project planning assumptions and will allow project detection goals to be met.
    - ii. Otherwise, verify that the RMS noise is within 10% of the mean of those previously measured at this location.
  - b. Background correct the survey data over the IVS using the patch over the blank spot.
  - c. Run the target location algorithm and verify that the resulting positions match the emplaced positions of each IVS item to 25 cm.
6. If the initial measurement quality objectives (MQOs) have not been met, the QC Geophysicist will initiate a root cause analysis to determine the source of the discrepancies. If modifications to the instrument or procedures can be made so that the MQOs can be met, these modifications will be made. If the MQOs cannot be met, for example if the initial background decay

amplitudes are too large, the Project and QC Geophysicist will meet with the project team to discuss potential resolutions.

7. Once the initial (or modified) MQOs have been met, the IVS survey will be complete and the system and operators verified for field data collection.

## 4. Data Management

### 4.1. Input Data Required

Input data required for this SOP are the locations and identities of the IVS items and the library polarizabilities for each.

### 4.2. Output Data

The test measurements over the IVS items described in Section 3.2.3, Step 5 will be saved in the project database along with the inversion results and library match metric for each of the measurements. Also, the QC checklists in Attachments 1 through 3 of this SOP will be completed, signed, and filed as proof of performance.

## 5. Quality Control

### 5.1. IVS Quality Control

This procedure is performed throughout the project and, therefore, has Preparatory, Initial and Follow-on QC checks. Performance of the required QC checks will be documented by the Field or Project Geophysicist on the Preparatory, Initial and Follow-on QC checklists in Attachments 1 through 3 to this SOP. The QC Geophysicist will verify and document successful completion of the following procedures in the Geophysics Daily QC Report:

- The Preparatory QC Checklist covers the construction of the IVS and preparation of the MetalMapper or TEMTADS prior to the first IVS tests. This checklist is completed once per project.
- The Initial QC Checklist covers the initial IVS tests to demonstrate proper functioning of the MetalMapper or TEMTADS system prior to performing production data acquisition.
- The Follow-on QC Checklist documents the IVS tests that are performed at least twice per day throughout the project, each morning prior to starting production data collection and at the conclusion of data collection.
- The QC tests in the following attachments will be performed as part of IVS procedure. In addition, instrument-specific start-up and function checks for the MetalMapper or TEMTADS will also be performed at start-up prior to all data collections including IVS data collection.
- Achievement of the IVS MQOs will be verified by the Field and QC Geophysicist on their QC checklists.
- During review of the Initial and Follow-on data packages, the Data Processor will overlay the polarizabilities of each IVS target from all measurements to observe the time variation of the

inverted results. Should an issue be detected (such as a data trend indicating a MQO limit is being approached) or a MQO is not met, a comprehensive root-cause analysis will be performed and a corrective action determined.

## **5.2. Measurement Quality Objective (MQOs)**

The MQOs for the IVS are presented in Worksheet #22 of the QAPP. The MetalMapper will not be used for field data collection until it is able to meet these MQOs or until the project team agrees on modifications to these MQOs.

## **6. Reporting**

This procedure will be documented through the completion of the Preparatory, Initial and Follow-on QC Checklists in Attachments 1 through 3. The IVS construction and implementation will be documented in an IVS Letter Report and a copy of the completed Preparatory Checklist from SOP 1 and the Preparatory and Initial Checklists from this SOP (including the MetalMapper or TEMTADS Start-up Checklist from Attachment 1 of SOP 1) will be included as attachments to that report. A Follow-on QC Checklist will be completed by the Field or Project Geophysicist each time IVS data is collected during the production survey and a copy of these completed checklists will be included with the Classification Project Report at the end of the project.

## SOP 2

### Attachment 1 Preparatory IVS Construction QC Checklist

This checklist is to be completed by the Field or Project Geophysicist during construction of the IVS. Construction of the IVS and completion of this checklist will be observed by the QC Geophysicist and verified in the Daily Geophysics QC Report.

QC Step	QC Process	Yes/No	Initial of Field or Project Geophysicist
1. Qualifications	Have the qualifications of the Project and Field Geophysicists and the Data Processor been verified?		
2. IVS Construction	Has an appropriate location for the IVS been selected i/a/w this SOP??		
3. IVS Construction	Have appropriate IVS seed targets been selected and procured i/a/w this SOP?		
4. IVS Construction	Has the background geophysical survey been performed i/a/w this SOP?		
5. IVS Construction	Were the target seeds buried appropriately, backfilled and marked i/a/w this SOP?		
6. IVS Construction	Is the required data on the IVS construction recorded for inclusion in the IVS Letter Report i/a/w this SOP?		

Field Geophysicist: \_\_\_\_\_ Date: \_\_\_\_\_

Project Geophysicist: \_\_\_\_\_ Date: \_\_\_\_\_

Data Processor: \_\_\_\_\_ Date: \_\_\_\_\_

## SOP 2 Attachment 2 Initial IVS QC Checklist

This checklist is to be completed by the Field or Project Geophysicist during the initial demonstration of the MetalMapper or TEMTADS performance on the IVS and observed and verified by the QC Geophysicist in the Geophysics Daily QC Report.

QC Step	QC Process and Guidance Reference	Yes/No	Initial of Field or Project Geophysicist
1. Preparation	Has the SOP 1 Preparatory Checklist been successfully completed?		
2. Preparation	Have the start-up procedures and pre-operation checklist from SOP 1 (Attachment 1) been successfully completed?		
3. Data collection	Is the IVS data collected i/a/w this SOP?		
4. Data processing	Did the Data Processor process the IVS i/a/w this SOP?		
5. Data analysis	Is the data collected on the blank space suitable for use as background i/a/w this SOP?		
6. Data analysis	Are all decay amplitudes below the threshold set in UX-Analyze i/a/w this SOP?		
7. Data analysis	Was the background data from the blank space used to correct the target data sets and to invert the data i/a/w this SOP?		
8. Data analysis	Do the resulting polarizibilities match the expected library values with a match statistic of 0.9 or greater i/a/w this SOP?		
9. MQO Documentation	Have the appropriate MQOs from Worksheet #22 been achieved?		

Field Geophysicist: \_\_\_\_\_ Date: \_\_\_\_\_

Project Geophysicist: \_\_\_\_\_ Date: \_\_\_\_\_

Data Processor: \_\_\_\_\_ Date: \_\_\_\_\_



## SOP 2

### Attachment 3 Follow-on IVS QC Checklist

This checklist is to be completed by the Field or Project Geophysicist every time IVS data is collected (at least twice per day at the beginning and end of each day's data collection). Performance of the IVS and completion of this checklist will also be observed by the QC Geophysicist and documented in the Geophysics Daily QC Report.

QC Step	QC Process	Yes/ No	Initial of Field or Project Geophysicist
1. Qualifications	Are the same geophysical personnel being used as in SOP 1? If not, have the qualifications of the new personnel been verified?		
2. Preparation	Have the start-up procedures and pre-operation checklist from SOP 1 (Attachment 1) been successfully completed?		
3. Data collection	Is the IVS data collected i/a/w this SOP?		
4. Data processing	Did the Data Processor process the IVS data i/a/w this SOP?		
5. Data analysis	Is the data collected on the blank space suitable for use as background i/a/w this SOP?		
6. Data analysis	Are all decay amplitudes within 10% of the mean of those previously measured at each location i/a/w this SOP?		
7. Data analysis	Was the background data from the blank space used to correct the target data sets and to invert the data i/a/w this SOP?		
8. Data analysis	Do the resulting polarizabilities match the expected library values with a match statistic of 0.9 or greater i/a/w this SOP?		
9. MQO Documentation	Have the appropriate MQOs from Worksheet #22 been achieved?		

Field Geophysicist: \_\_\_\_\_

Project Geophysicist: \_\_\_\_\_

Data Processor: \_\_\_\_\_

## STANDARD OPERATING PROCEDURE 3

### Production Area Seeding

---

#### 1. Purpose and Scope

The purpose of this Standard Operating procedure (SOP) is to identify the methods to be employed when emplacing QC or validation seeds in the production area.

#### 2. Personnel, Equipment and Materials

This section describes the personnel, equipment and materials required to implement this SOP.

The following individuals will be involved in production area seeding:

- Project Geophysicist
- QC Geophysicist

UXO Personnel will be responsible for overall daily site access and safety aspects of the project, compiling subcontractor health and safety documents, conducting daily safety briefings and performing munitions and explosives of concern (MEC) avoidance, as needed, in the field. Information on the specific qualifications for various UXO personnel support roles can be found in the project Health and Safety Plan.

The qualifications of the personnel implementing this SOP are documented in the QAPP Worksheet #4, 7 & 8.

The following is a list of required equipment and materials:

- inert munitions and schedule 80 small ISOs (small ISO80) to emplace the seeds
- hand-held geophysical sensor (typically a Schonstedt magnetic locator or White's metal detector)
- hand tools including shovels, pick axes, breaker bars, etc. to emplace the seeds
- excavators if required by the production seed plan
- RTK GPS unit to record the location of seed items
- meter stick and straight edge to measure the depth of the seeded items
- level or inclinometer and compass to measure the inclination and orientation of the seeded items

#### 3. Procedures and Guidelines

The production area seed plan provides a list of seed identities, locations, depths, and orientations. When emplacing the seeds, the emplacement team should employ anomaly avoidance techniques as described in Section 3.1 and use the emplacement procedure described in Section 3.2.

### 3.1. Anomaly Avoidance

It is likely that the demonstration area will contain some metallic items or electromagnetically active geology. These will produce anomalies in data collected with a magnetometer or electromagnetic induction instrument. The emplacement team should avoid emplacing seeds in the immediate vicinity of any strong anomalies. Figure 1 describes the process that should be used to avoid strong anomalies when emplacing a seed. First, the emplacement team should acquire the seed's intended location. Then, the team should use a hand-held instrument to survey within the immediate vicinity (30 to 40 cm radius) of the intended location. If there are no strong anomalies in the immediate vicinity, then the team should emplace the seed at the intended location. If, however, the intended location is in the immediate vicinity of any strong anomaly, then the team should select a new location for the seed, as close as safety allows. The new location should ***not*** be within the immediate vicinity of any strong anomaly and should ***not*** be within 60 cm of another seed.

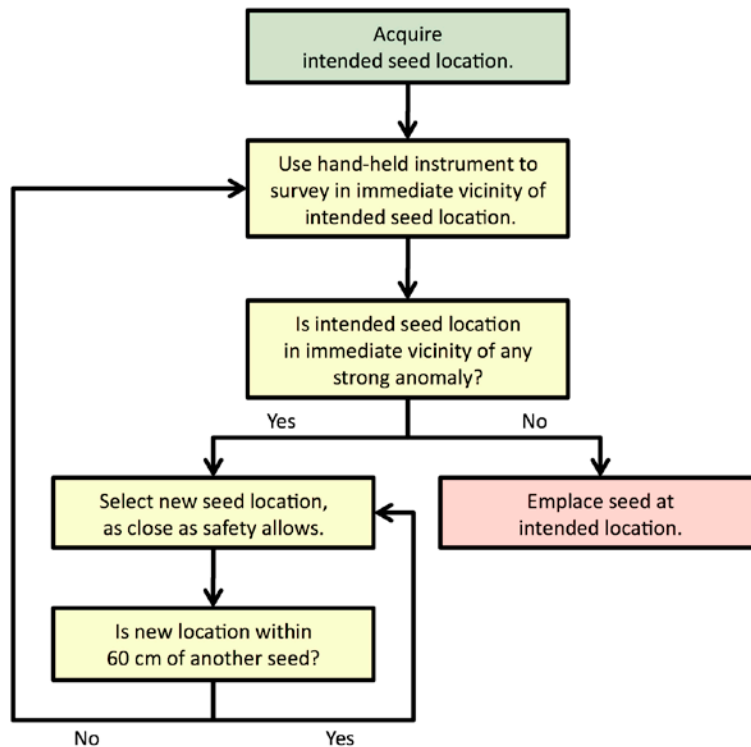


Figure 1: Anomaly avoidance during seed emplacement.

### 3.2. Seed Emplacement

The study will attempt to reconstruct the physical parameters of the buried targets, such as location, depth, inclination, azimuth, and size. Therefore it is critical for the success of the study that the ***actual locations*** of the buried seeds are surveyed as accurately and precisely as possible. To that end, the emplacement team should dig in a fashion to minimize seed migration (e.g., settling) after burial.

The production area seed plan specifies the seeds' intended burial parameters. The intended locations are given to 1 cm precision, with the intended depths to 2 cm precision and the intended inclinations and azimuths to 15 degree precision. All locations should be acquired as accurately and precisely as possible before digging begins, as this ensures anomaly avoidance. Locations should be surveyed relative to a cm-level control point.

This plan is merely a **guide** for seed emplacement. The emplacement team may allow small deviations from the intended burial parameters listed in the attached spreadsheet. This variation is desired and the exact parameters should be recorded by survey. For example, the inclinations are specified to within 45 degrees of horizontal or vertical down. Therefore, the emplacement team should avoid burying the seeds exactly horizontal or exactly vertical down. In addition, the emplacement team should adjust the inclination angles of the seeds to ensure 5 cm of overburden.

After emplacing a seed in the ground, but before covering it with dirt, the following information should be carefully recorded:

- the x, y, and z coordinates for the center of the seed, with coordinates reported in UTM (NAD 83) meters
- the depth of the seed, measured as the vertical distance from the bottom of a straight edge placed across the opening of the hole down to the center of the seed
- a photograph of the seed, showing its serial number. A ruler or similar scale should also be included in the photograph.

For each seed, the emplacement team should also:

- ensure the seed is marked with blue paint (inert).
- replace any metallic items that were found in the hole (i.e., emplace the metallic items in the hole along with the seed).
- replace dirt in the hole as completely as possible.
- level the burial location.
- replace the grass plug over the burial location (if possible).

## 4. Data Management

The following sections describe the data that is needed to perform this SOP and the resulting data.

### 4.1. Input Data Required

The production area seed plan which contains a table of seed items, initial locations, and depths and orientations is required for this SOP.

### 4.2. Output Data

The output data from this SOP is the final production area seed report. This report consists of a brief narrative describing the seed emplacement and a discussion of significant deviations from the seed plan.

The bulk of the report consists of a seed location table that includes the “as emplaced” identity, location, depth, and orientation of each of the emplaced seeds accompanied by a photograph of the item in the ground before being covered.

## **5. Quality Control**

The measurement quality objective (MQO) (QAPP Worksheet #22) for this SOP is verification that all seeds have been emplaced with the specified precision. No field work will be performed until this has been documented as described below.

## **6. Reporting**

This procedure will be documented through the completion of the Preparatory QC Checklist in Attachment 1. Production area seeding will be documented in Production Area Seed Report as described in Section 4.2.

### SOP 3

#### Attachment 1 Preparatory Production Area Seeding QC Checklist

This checklist is to be completed by the QC or Project Geophysicist following completion of production area seeding. Placement of the production area QC seeds will be observed by the QC Geophysicist and verified in the Daily Geophysics QC Report.

QC Step	QC Process and Guidance Reference	Yes/No	Initial of Field or Project Geophysicist
1. Qualifications	Have the qualifications of the Project and QC Geophysicists listed in QAPP Worksheet #4, 7 & 8 been verified?		
2. Preparation	Have appropriate production area seed targets been selected and procured?		
3. Seed Emplacement	Were the target seeds buried appropriately, measured, photographed, and backfilled?		
4. Completion of Task	Has the production area seed report been prepared i/a/w this SOP?		

QC Geophysicist: \_\_\_\_\_ Date: \_\_\_\_\_

Project Geophysicist: \_\_\_\_\_ Date: \_\_\_\_\_

## STANDARD OPERATING PROCEDURE 4M

### Perform Dynamic Surveys with MetalMapper

---

#### 1. Purpose and Scope

The purpose of this Standard Operating procedure (SOP) is to identify the means and methods to be employed when performing dynamic surveys using a MetalMapper advanced electromagnetic induction (EMI) sensor for target detection.

Dynamic MetalMapper data collection involves navigating the sensor along transects at a transect spacing designed to meet the project objectives with respect to detection performance of suspected targets of interest (TOI) in the subsurface. The detection objectives and resultant transect spacing are identified in the project-specific QAPP.

The observed signal measured by the MetalMapper is composed of 1) the EMI response of potential buried targets, 2) the self-signature of the sensor system, and 3) any response from the ambient environment in which the target is buried. To isolate responses associated with buried discrete metal objects, a background model comprised of the latter two contributing signals must be derived and removed from the raw data. The resulting 'leveled' signal data, (raw data – background model) are used as inputs into a detection algorithm where anomalous responses due to potential targets of interest are mapped and selected for further investigation. Details of the data processing and analysis of dynamic data are covered in SOP 5.

#### 2. Personnel, Equipment and Materials

This section describes the personnel, equipment, and materials required to implement this SOP.

The following individuals will be involved in the collection of dynamic survey data:

- Project Geophysicist
- QC Geophysicist
- Field Team Leader
- Data Processor

The qualifications of the personnel implementing this SOP are documented in the QAPP Worksheet #4, 7 & 8.

The following is a list of required equipment and materials:

- MetalMapper sensor coupled with a real-time kinematic Global Positioning System (RTK GPS) and Inertial Measurement Unit (IMU) for orientation measurements
- transport vehicle (skid steer, tractor, extended reach forklift) used to move the MetalMapper during data collection
- field survey grade tape measure

### 3. Procedures and Guidelines

#### 3.1. Survey Grid Preparation

Grid preparation involves demarking the site boundaries and survey transects required to achieve the coverage specified in the project-specific QAPP. The site will be subdivided into grids with sizes depending upon the site conditions such that the sensor can be precisely navigated along the desired transect. Survey transect locations will be generated using the “survey layout” function in UX-Detect. The generated lines will be exported in a .XYZ file that can be imported into EM3D, the MetalMapper’s data collection software. Data collection transect locations will also be developed for the IVS.

#### 3.2. Function Test Measurements

Function test measurements (described in SOP 1) will be performed prior to each sortie to confirm that all transmit and receive components of the MetalMapper sensor are operational.

#### 3.3. Daily IVS Survey

Prior to the start and at the end of each day of data collection, measurements of the set of IVS targets will be performed (described in SOP 2).

#### 3.4. Dynamic Data Collection

Dynamic survey for DGM involves collecting data along transects across the survey area. In combination with SOPs for sensor assembly (SOP 1) and testing at the IVS (SOP 2), in-motion data is collected along each transect at a spacing appropriate to the site and project needs, as defined in the project-specific QAPP. Data collection is controlled by the user with the EM-3D software, which allows the user to assign a numerical ID to each transect line and start/stop data collection at the beginning/end of each transect. When an obstacle is encountered along a transect, the obstacle can be avoided by either altering the path of the transect or stopping data collection when the obstacle is encountered and resuming a new ID transect on the other side of the obstacle. Data gaps that are the result of obstacles should be recorded by the field geophysicist and submitted to the data processor. Data gaps that are the result of line spacing over the defined acceptable spacing will be determined by the data processor and provided to the field geophysicist for recollection. Data acquisition will be performed using the following steps:

1. **Start-up and test the MetalMapper.** The geophysical and navigation systems are started and a function test is performed prior to every data collection sortie. In addition the data acquisition software is monitored to ensure that all data streams (EMI, global positioning system, [GPS], and inertial measurement unit [IMU]) are valid and being recorded.
2. **Navigate and collect data along transects.** Navigation along transects is by following the survey lines plotted on the MetalMapper screen. Positioning in the data is captured through the use of the RTK GPS system and the IMU.



3. **Verify the integrity and quality of the collected data.** During data acquisition, the integrity and quality of the data will be verified by the operator by inspection of the MetalMapper data collection screen to ensure that:
  - the data collection starts and stops in coordination with the beginning and end of each transect.
  - each transect is assigned a unique numerical identifier (ID), in sequential order.
  - the amplitude responses measured by each receiver coil appear reasonable (i.e., not ‘flat-lined’).
4. **Verify complete coverage of survey area.** 100% coverage surveys will require appropriate line spacing (presented in QAPP Worksheet #12). Data gaps resulting from obstacles or inaccessible terrain will be marked and verified by the field geophysicist. Data gaps exceeding the MQOs identified in QAPP Worksheet #22 will be reacquired using RTK GPS and recollected.

## 4. Data Management

### 4.1. Data inputs

The data inputs required are:

- A list of coordinates identifying the site boundaries
- A list of instrument verification strip (IVS) transect start and end points

### 4.2. Data Outputs

The data outputs are:

- dynamic MetalMapper transect data over the IVS line and survey area
- function test measurement data
- raw field notes (pdf images of hand written notes)
- digital field notes (an Excel, MS Access, or other digitally recorded table presenting data filenames as delivered and rectified field notes [i.e. differences between delivered digital filenames and field notes are resolved])

## 5. Quality Control

Practical considerations limit the real-time quality control (QC) of the dynamic data acquisition activities to qualitative assessments. Quantitative QC and assessment of the collected data will be performed as part of SOP 5M dealing with the processing of dynamic MetalMapper detection data. The Quality Control checklist presented as Attachment 1 to this SOP will be filled out and delivered as part of the reporting requirement for this SOP.

The measurement quality objectives (MQOs) for dynamic data acquisition are presented in Worksheet #22 of the project-specific QAPP. Performance relative to the MQOs will be assessed during the

processing of the collected data (SOP 5M). Dynamic MetalMapper data will not be used to detect targets until these MQOs are met or until the project team agrees on modifications to these MQOs.

## **6. Reporting**

Reporting of the activities associated with this SOP will consist of the digital copies of the field notes and completion of the checklist provided in Attachment 1.

## SOP 4M

### Attachment 1 Dynamic MetalMapper Data Collection QC Checklist

This checklist is to be completed by the Field or Project Geophysicist each day dynamic TEMTADS data are collected.

QC Step	QC Process	Yes/No	Initial of Field or Project Geophysicist
1. Preparation	Has the SOP 1 checklist detailing the proper assembly and operation of the TEMTADS sensor for Dynamic detection surveys been completed (or recompleted as required due to equipment modifications)?		
2. Function Tests	Were function tests performed a minimum of twice per day and did all function tests pass using the real-time assessment?		
3. IVS Tests	Were transect surveys conducted over the IVS items at the start and end of the day with exceptions noted in the field notes?		
4. Sensor Navigation	For the dynamic data collected, were valid data collected along the intended transects with any exceptions or gaps in coverage noted in the field notes?		
5. Data Measurements	For the dynamic data collection (including IVS measurements), was the system monitored with regard to transmit current, receiver decay curves and any exceptions noted in the field notes?		
6. Reporting	Were the field notes converted to digital format and filenames resolved with regard to the field notes?		

Field Geophysicist: \_\_\_\_\_ Date: \_\_\_\_\_

Project Geophysicist: \_\_\_\_\_ Date: \_\_\_\_\_

Data Processor: \_\_\_\_\_ Date: \_\_\_\_\_

## STANDARD OPERATING PROCEDURE 4T

### Perform Dynamic Surveys with TEMTADS 2x2

---

#### 1. Purpose and Scope

The purpose of this Standard Operating procedure (SOP) is to identify the means and methods to be employed when performing dynamic surveys using a TEMTADS 2x2 (TEMTADS) advanced electromagnetic induction (EMI) sensor for target detection.

Dynamic TEMTADS data collection involves navigating the sensor along transects at a transect spacing designed to meet the project objectives with respect to detection performance of suspected targets of interest (TOI) in the subsurface. The detection objectives and resultant transect spacing are identified in the project-specific QAPP.

The observed signal measured by the TEMTADS is composed of 1) the EMI response of potential buried targets, 2) the self-signature of the sensor system, and 3) any response from the ambient environment in which the target is buried. To isolate responses associated with buried discrete metal objects, a background model comprised of the latter two contributing signals must be derived and removed from the raw data. The resulting 'leveled' signal data, (raw data – background model) are used as inputs into a detection algorithm where anomalous responses due to potential targets of interest are mapped and selected for further investigation. Details of the data processing and analysis of dynamic data are covered in SOP 5T.

#### 2. Personnel, Equipment and Materials

This section describes the personnel, equipment, and materials required to implement this SOP.

The following individuals will be involved in the collection of dynamic survey data:

- Project Geophysicist
- QC Geophysicist
- Field Team Leader
- Data Processor

The qualifications of the personnel implementing this SOP are documented in the QAPP Worksheet #4, 7 & 8.

Required equipment includes:

- TEMTADS sensor coupled with a real-time kinematic Global Positioning System (RTK GPS) and orientation sensor
- Archos Tablet
- field survey grade tape measure

Required material includes

- traffic cones or equivalent for lane marking, or
- marking paint

### 3. Procedures and Guidelines

#### 3.1. Survey Grid Preparation

Grid preparation involves demarking the site boundaries and survey transects required to achieve the coverage specified in the project-specific QAPP. The site will be subdivided into grids with sizes depending upon the site conditions such that the sensor can be precisely navigated along the desired transect. The transect ends will be measured and pre-marked. Traffic cones will be used to identify the start and end of each transect as it is transgressed.

#### 3.2. Function Test Measurements

Function test measurements (described in SOP 1) will be performed prior to each sortie to confirm that all transmit and receive components of the TEMTADS sensor are operational.

#### 3.3. Daily IVS Survey

Prior to the start and at the end of each day of data collection, measurements of the set of IVS targets will be performed (described in SOP 2).

#### 3.4. Dynamic Data Collection

Dynamic survey for DGM involves collecting data along transects across the survey area. In combination with SOPs for sensor assembly (SOP 1) and testing at the IVS (SOP 2), in-motion data is collected along each transect at a spacing appropriate to the site and project needs, as defined in the project-specific QAPP. Data collection is controlled by the user with the EM-3D software, which allows the user to assign a numerical ID to each transect line and start/stop data collection at the beginning/end of each transect. When an obstacle is encountered along a transect, the obstacle can be avoided by either altering the path of the transect or stopping data collection when the obstacle is encountered and resuming a new ID transect on the other side of the obstacle. Data gaps that are the result of obstacles should be recorded by the field geophysicist and submitted to the data processor. Data gaps that are the result of line spacing over the defined acceptable spacing will be determined by the data processor and provided to the field geophysicist for recollection. Data acquisition will be performed using the following steps:

1. **Start-up and test the TEMTADS.** The geophysical and navigation systems are started and a function test is performed prior to every data collection sortie. In addition the data acquisition software is monitored to ensure that all data streams (EMI, global positioning system, [GPS], and inertial measurement unit [IMU]) are valid and being recorded.
2. **Navigate and collect data along transects.** Navigation along transects is performed visually with the assistance of markers, which are determined at the discretion of the field geophysicist. They

may include, but are not limited to, ropes, tapes, spray paint, or flags. This can be accomplished by marking the track of the inside wheels as the sensor moves along a transect. Positioning in the data is captured through the use of the RTK GPS system and the IMU.

3. **Verify the integrity and quality of the collected data.** During data acquisition, the integrity and quality of the data will be verified by the operator by inspection of the TEMTADS data collection screen to ensure that:
  - the data collection starts and stops in coordination with the beginning and end of each transect.
  - each transect is assigned a unique numerical identifier (ID), in sequential order.
  - the amplitude responses measured by each receiver coil appear reasonable (i.e., not ‘flat-lined’).
4. **Verify complete coverage of survey area.** 100% coverage surveys will require appropriate line spacing (presented in QAPP Worksheet #12). Data gaps resulting from obstacles or inaccessible terrain will be marked and verified by the field geophysicist. Data gaps exceeding the MQOs identified QAPP Worksheet #22 will be reacquired using RTK GPS and recollected.

## 4. Data Management

### 4.1. Data Inputs

The data inputs required are:

- a list of coordinates identifying the site boundaries.
- a list of instrument verification strip (IVS) transect start and end points.

### 4.2. Data Outputs

The data outputs are:

- dynamic TEMTADS transect data over the IVS line and survey area.
- function test measurement data.
- raw field notes (pdf images of hand written notes).
- digital field notes (an excel or other digitally recorded table presenting data filenames as delivered and rectified field notes [i.e. differences between delivered digital filenames and field notes are resolved]).

## 5. Quality Control

Practical considerations limit the real-time quality control (QC) of the dynamic data acquisition activities to qualitative assessments. Quantitative QC and assessment of the collected data will be performed as part of SOP 5T dealing with the processing of dynamic TEMTADS detection data. The Quality Control checklist presented as Attachment 1 to this SOP will be filled out and delivered as part of the reporting requirement for this SOP.

The measurement quality objectives (MQOs) for dynamic data acquisition are presented in Worksheet #22 of the project-specific QAPP. Performance relative to the MQOs will be assessed during the processing of the collected data (SOP 5T). Dynamic TEMTADS data will not be used to detect targets until these MQOs are met or until the project team agrees on modifications to these MQOs.

## **6. Reporting**

Reporting of the activities associated with this SOP will consist of the digital copies of the field notes and completion of the checklist provided in Attachment 1.

## SOP 4T

### Attachment 1 Dynamic TEMTADS Data Collection QC Checklist

This checklist is to be completed by the Field or Project Geophysicist each day dynamic TEMTADS data are collected.

QC Step	QC Process	Yes/No	Initial of Field or Project Geophysicist
1. Preparation	Has the SOP 1 checklist detailing the proper assembly and operation of the TEMTADS sensor for Dynamic detection surveys been completed (or recompleted as required due to equipment modifications)?		
2. Function Tests	Were function tests performed a minimum of twice per day and did all function tests pass using the real-time assessment?		
3. IVS Tests	Were transect surveys conducted over the IVS items at the start and end of the day with exceptions noted in the field notes?		
4. Sensor Navigation	For the dynamic data collected, were valid data collected along the intended transects with any exceptions or gaps in coverage noted in the field notes?		
5. Data Measurements	For the dynamic data collection (including IVS measurements), was the system monitored with regard to transmit current, receiver decay curves and any exceptions noted in the field notes?		
6. Reporting	Were the field notes converted to digital format and filenames resolved with regard to the field notes?		

Field Geophysicist: \_\_\_\_\_ Date: \_\_\_\_\_

Project Geophysicist: \_\_\_\_\_ Date: \_\_\_\_\_

Data Processor: \_\_\_\_\_ Date: \_\_\_\_\_



## STANDARD OPERATING PROCEDURE 5M

### Process Dynamic Survey Data - MetalMapper

---

#### 1. Purpose and Scope

The purpose of this Standard Operating procedure (SOP) is to identify the means and methods to be employed when processing dynamic survey data collected using a MetalMapper advanced electromagnetic induction (EMI) sensor for target detection.

Dynamic MetalMapper data collection involves navigating the sensor along transects at a transect spacing designed to meet the project objectives with respect to detection performance of suspected targets of interest (TOI) in the subsurface. The detection objectives and resultant transect spacing are identified in the Geophysical Classification for Munitions Response (GCMR) Quality Assurance Project Plan (QAPP). Processing the dynamic data involves processing and assessing all QC tests (including daily function tests and IVS surveys), leveling the raw data to remove EMI signal due to the self-signature of the sensor systems and the ambient EMI soil response, and target selection.

A set of QC measurements are conducted upon initial commissioning of the system and on a daily basis to validate the operation of the various components of the MetalMapper dynamic survey system.

In the dynamic survey data, the observed signal measured by the MetalMapper is composed of 1) the EMI response of potential buried metallic objects, 2) the self-signature of the sensor system, and 3) any response from the ambient environment in which the target is buried. To isolate responses associated with buried discrete metal objects, a background model comprised of the latter two contributing signals must be derived and removed from the raw data. The resulting 'leveled' signal data (raw data – background model) are used as inputs into a detection algorithm where anomalous responses due to potential TOI are mapped and selected for further investigation.

#### 2. Personnel and Equipment

This section describes the personnel and equipment required to implement this SOP.

The following individuals will be involved in the analysis of dynamic data:

- Project Geophysicist
- QC Geophysicist
- Data Processor

The qualifications of the personnel implementing this SOP are documented in the QAPP Worksheet #4, 7 & 8.

The only required equipment is a data processing computer suitable for and equipped to run the processes provided in the UXA-advanced module of Geosoft's Oasis montaj geophysical processing environment.

### 3. Procedures and Guidelines

This section describes the procedures used to process the dynamic production data including positioning and leveling of the data, process/assess the QC activities related to dynamic data collection, and select target anomalies from the final processed data.

#### 3.1. Processing of Dynamic MetalMapper data

The processing of dynamic MetalMapper data is achieved in the following steps:

- data import and QC
- data positioning and background removal
- target selection

##### 3.1.1. Data Import/Initial QC

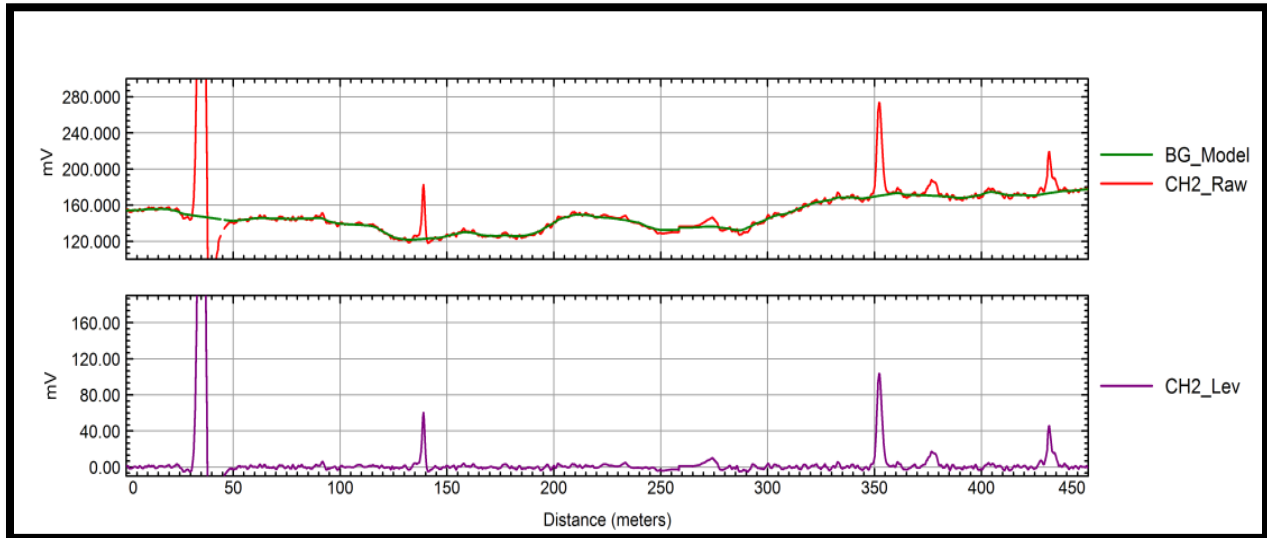
The raw \*.TEM data files are converted to ASCII \*.csv files using EM3D Plot export utility and imported into a Geosoft Database (\*.gdb) using a purpose built utility in UXA-Advanced. Once imported the data are inspected and assessed against the measurement quality objectives (MQOs) provided in Worksheet #22 for:

- transmit (Tx) current within limits
- global positioning system (GPS) fit quality
- valid inertial measurement unit (IMU) data
- EMI response signal not saturated

Data measurements that do not pass the MQOs are automatically identified by a series of scripts that are used to default the position data where the MQOs are not met. This maintains the chronologic integrity of the EMI data but prevents the out-of-specification data from being mapped and used for detection.

##### 3.1.2. Data Positioning and Leveling

A second purpose-built software routine automatically assigns the monostatic, Z-component EMI measurements positions based upon the GPS antenna location, platform geometry and platform attitude (IMU) data. A site-specific de-median filter is applied to the raw monostatic, Z-component data to derive an estimate of the background model. This model is subtracted from the raw data to provide a background removed or 'leveled' data set. Figure 1 shows an example of raw data (top panel, red trace), the background model derived from these data (top panel, green trace) and the resulting background removed data.



**Figure 1.** Example of Raw and Leveled Data

The leveled monostatic data are gridded and mapped using conventional Geosoft tools. The mapped monostatic Z-component data are then used for amplitude response based target selection whereby the position of peak responses in the data that exceed the project threshold are selected and identified as target anomalies for further analysis.

The gridded and mapped monostatic Z-component data are also suitable for use to select background locations, which in turn can be used to level all of the 21 Receive (Rx) coil channels in a manner similar to that used for background removal of cued target measurements.

### 3.1.3. Target Selection

Target selection using the MetalMapper dynamic data is performed using the traditional amplitude response metric using the mapped Z-component data described above. Alternately a dipole response filter approach or other advanced anomaly selection technique that uses a larger subset of the available data can be used.

#### 3.1.3.1. Response Amplitude Detection:

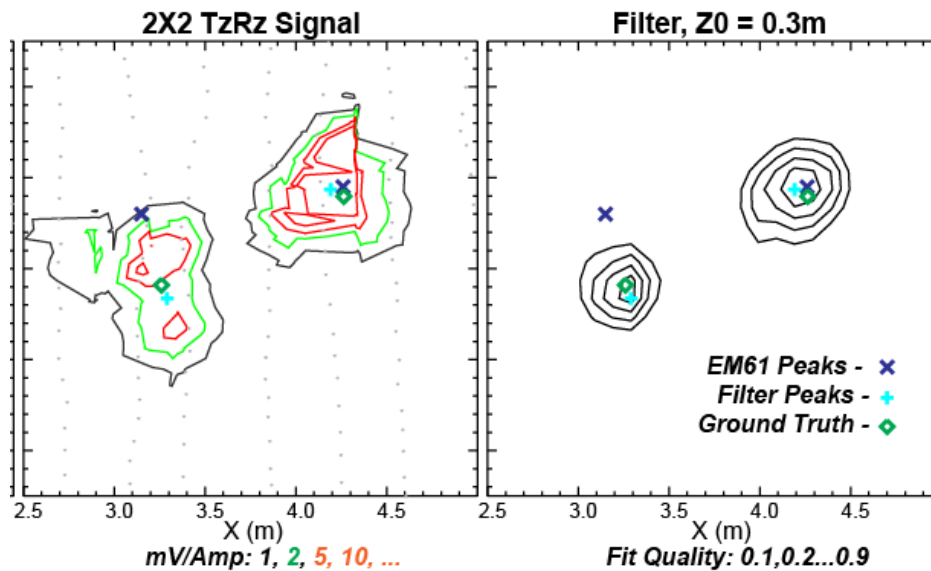
Traditional anomaly selection is based almost entirely on signal response amplitude. Using the MetalMapper dynamic survey monostatic Z-component response amplitude as a detection metric is essentially the same as using a Geonics EM61 response amplitude detection. After the data have been gridded, the Geosoft automatic grid peak detection algorithm is used to extract locations of all grid peaks that are above the project detection threshold. These target anomaly locations are reviewed by the project geophysicist and manual additions and deletions are made to this list. The final list is reviewed by the quality control (QC) geophysicist prior to finalization of the target list.

### 3.1.3.2. Dipole Response Filter Detection:

The 'dipole response filter' approach to anomaly detection makes use of the rich data set output of the advanced sensors. This target selection routine takes advantage of all the measured data – not just the monostatic Z component – by employing an automated dipole inversion routine to estimate the source locations. The process involves:

- assuming a target's location (at every 10 centimeter [cm] spaced grid node across the site).
- extracting data within a specified sensor footprint.
- inverting for dipole polarizations.
- extracting the 'goodness-of-fit parameter' as the detection metric.

The 'goodness-of-fit' filter output is the squared correlation between the full multi-axis, multi-static MetalMapper data set and a dipole model fit to those data. This filter output is mapped in the same manner as the amplitude response and peaks in the detection metric indicate target locations as illustrated by Figure 2.



**Figure 2.** Data subset showing mapped response amplitude (left) and mapped filter response output (right) with ground truth information superimposed. Contour line values are provided in the legend.

Accordingly, target selection using the dipole filter fit coherence metric is accomplished in the same manner as for the amplitude response approach. After running the automatic peak detection routine, the target list will be reviewed and manual additions/deletions will be made.

### 3.2. Assessment of Quality Control of Dynamic Survey Data

During the course of a dynamic survey, QC measurements are performed on a daily basis to verify the operation of the sensor and associated components. These tests are comprised of function tests

(described in SOP 1) and transects along the instrument verification strip (IVS). The successful completion of these tests on a daily basis is required to validate the survey data collected on that day.

### **3.2.1. Function Test Measurement Processing**

Function test measurements (described in SOP 1) are performed prior to each sortie to confirm that all transmit and receive components of the MetalMapper sensor are operational. The data from each function test are assessed relative to the MQOs presented in Worksheet #22, compiled and presented in graphical form for review. Results that do not pass the MQOs are identified and the appropriate action specified in Worksheet #22 is taken.

### **3.2.2. Daily IVS Survey Processing**

Prior to the start and at the end of each day of data collection, measurements of the set of IVS targets are performed (described in SOP 2). These data are processed in the same manner as the production survey data with regard to positioning and background removal. The data from each IVS test are assessed relative to the MQOs presented in Worksheet #22, compiled and presented in graphical form for review. Results that do not pass the MQOs are identified and the appropriate action specified in Worksheet #22 (root cause analysis [RCA]/corrective action [CA]) are taken. Depending upon the findings of the RCA, the survey data associated with the IVS MQO failure may need to be re-collected.

## **4. Data Management**

### **4.1. Data inputs**

The data inputs required for processing dynamic MetalMapper data are:

- a list of coordinates identifying the site boundaries
- raw dynamic MetalMapper data files
- amplitude response minimum detection threshold (derived from the project-specific QAPP)

### **4.2. Data Outputs**

The data outputs of the processing of dynamic MetalMapper data are:

- QC reports summarizing daily QC measurement results
- mapped detection metric data (Z-component amplitude and dipole response coherence) in ASCII (x,y,z) format
- target anomaly list (identifier [ID], X, Y)
- letter report detailing processing approach including leveling and target selection procedures

## **5. Quality Control**

The Quality Control checklist presented as Attachment 1 to this SOP will be filled out and delivered as part of the reporting requirement for this SOP.

The MQOs for processing dynamic MetalMapper data are presented in Worksheet #22 of the project-specific QAPP. Performance relative to the MQOs will be assessed during the processing of the data. Dynamic MetalMapper data will not be used to select targets until these MQOs are met or until the project team agrees on modifications to these MQOs.

## 6. Reporting

Reporting of the activities associated with this SOP will consist of the following:

- digital Field notes
- data processing log detailing the following for each sortie (chronologically contiguous data collection set):
  - survey date
  - % invalid data with regard to transmit (Tx) current, GPS fix quality, IMU data quality, EMI response within range
  - standard quality control checks performance
    - correct coordinates for grids
    - coverage
    - line gaps
    - background response
    - dropouts
    - downline density
    - appropriate leveling
    - appropriate anomaly selection
  - associated Function Test filename
  - associated IVS Test filename(s)
  - area subset (grid ID)
- QC report summarizing daily QC results (Function tests and IVS tests)
- target list – final list of identified anomalies for delivered area subset
- final data archive (gdb or xyz format) for delivered area subset
- final grids of Z-component amplitude response for delivered area subset
- final grids of detection metric (if not amplitude response) for delivered area subset
- processing/data selection letter report

## SOP 5M

### Attachment 1 Dynamic MetalMapper Data Processing QC Checklist

This checklist is to be completed by the data processor or Project Geophysicist for every delivered data set (usually a contiguous subset of the project survey area).

QC Step	QC Process	Yes/ No	Initial of Field or Project Geophysicist
1. Function Tests	Was the functionality of the MetalMapper EMI components verified for each sortie using function tests and did all function tests pass the MQO for this test?		
2. IVS Tests	Was the functionality of the MetalMapper system verified for each sortie using IVS tests and did all IVS tests pass the associated MQOs?		
3. Data Validity	Were invalid data for each sortie (with regard to Tx current, GPS fit quality, IMU data quality, and EMI response within range) identified and rejected?		
4. Coverage	Were gaps in data coverage due to down-line and across line sampling identified and accounted for (obstructions)?		
5. Background removal	Was the background model inspected prior to subtraction from the raw data and was the leveling reviewed by the QC Geophysicist?		
6. Target selection	Was the final target list reviewed by the data processor and the QC geophysicist?		
7. Reporting/deliverables	Were the following documents completed and delivered: <ul style="list-style-type: none"> <li>• Digital Field notes</li> <li>• Data processing log</li> <li>• Target List</li> <li>• Final data archive (gdb or xyz format)</li> <li>• Final grids</li> </ul>		

Data Processor: \_\_\_\_\_ Date: \_\_\_\_\_

Project Geophysicist: \_\_\_\_\_ Date: \_\_\_\_\_

## STANDARD OPERATING PROCEDURE 5T

### Process Dynamic Survey Data - TEMTADS 2x2

---

#### 1. Purpose and Scope

The purpose of this Standard Operating procedure (SOP) is to identify the means and methods to be employed when processing dynamic survey data collected using a TEMTADS 2x2 (TEMTADS) advanced electromagnetic induction (EMI) sensor for target detection.

Dynamic TEMTADS data collection involves navigating the sensor along transects at a transect spacing designed to meet the project objectives with respect to detection performance of suspected targets of interest (TOI) in the subsurface. The detection objectives and resultant transect spacing are identified in the Geophysical Classification for Munitions Response (GCMR) Quality Assurance Project Plan (QAPP). Processing the dynamic data involves processing and assessing all QC tests (including daily function tests and IVS surveys), leveling the raw data to remove EMI signal due to the self-signature of the sensor systems and the ambient EMI soil response, and target selection.

A set of QC measurements are conducted upon initial commissioning of the system and on a daily basis to validate the operation of the various components of the TEMTADS dynamic survey system.

In the dynamic survey data, the observed signal measured by the TEMTADS is composed of 1) the EMI response of potential buried metallic objects, 2) the self-signature of the sensor system, and 3) any response from the ambient environment in which the target is buried. To isolate responses associated with buried discrete metal objects, a background model comprised of the latter two contributing signals must be derived and removed from the raw data. The resulting 'leveled' signal data, (raw data – background model) are used as inputs into a detection algorithm where anomalous responses due to potential TOI are mapped and selected for further investigation.

#### 2. Personnel and Equipment

This section describes the personnel and equipment required to implement this SOP.

The following individuals will be involved in the analysis of dynamic data:

- Project Geophysicist
- QC Geophysicist
- Data Processor

The qualifications of the personnel implementing this SOP are documented in the QAPP Worksheet #4, 7 & 8.

The only required equipment is a data processing computer suitable for and equipped to run the processes provided in the UXA-advanced module of Geosoft's Oasis Montaj geophysical processing environment.



### 3. Procedures and Guidelines

This section describes the procedures used to process the dynamic production data including positioning and leveling of the data, process/assess the QC activities related to dynamic data collection, and select target anomalies from the final processed data.

#### 3.1. Processing of Dynamic TEMTADS data

The processing of dynamic TEMTADS data is achieved in the following steps:

1. Data import and QC
2. Data positioning and background removal
3. Target selection

##### 3.1.1. Data Import/initial QC

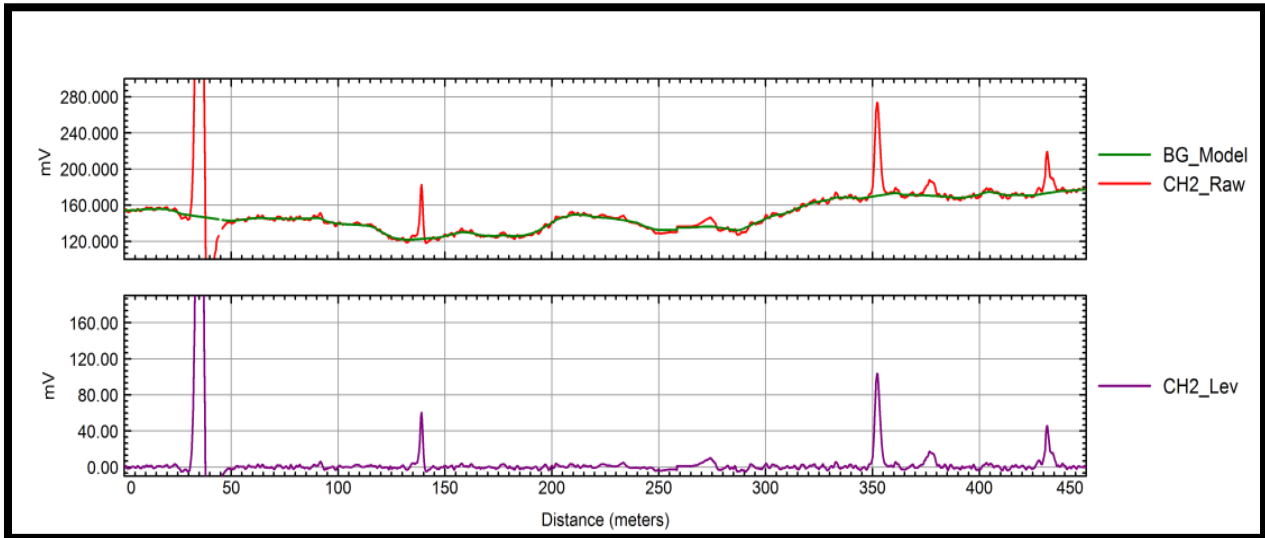
The raw \*.TEM data files are converted to ASCII \*.csv files using Convert\_TEMTADS and imported into a Geosoft Database (\*.gdb) using a purpose built utility in UX-Advanced. Once imported the data are inspected and assessed against the measurement quality objectives (MQOs) provided in Worksheet #22 for:

- transmit (Tx) current within limits
- Global positioning system (GPS) fit quality
- valid inertial measurement unit (IMU) data
- EMI response signal not saturated

Data measurements that do not pass the MQOs are automatically identified by a series of scripts that are used to default the position data where the MQOs are not met. This maintains the chronologic integrity of the EMI data but prevents the out-of-specification data from being mapped and used for detection.

##### 3.1.2. Data Positioning and Leveling

A second purpose-built software routine automatically assigns the monostatic, Z-component EMI measurements positions based upon the GPS antenna location, platform geometry and platform attitude (IMU) data. A site-specific de-median filter is applied to the raw monostatic, Z-component data to derive an estimate of the background model. This model is subtracted from the raw data to provide a background removed or 'leveled' data set. Figure 1 shows an example of raw data (top panel, red trace), the background model derived from these data (top panel, green trace) and the resulting background removed data.



**Figure 1.** Example of Raw and Leveled Data

The leveled monostatic data are gridded and mapped using conventional Geosoft tools. The mapped monostatic Z-component data are then used for amplitude response based target selection whereby the position of peak responses in the data that exceed the project threshold are selected and identified as target anomalies for further analysis.

The gridded and mapped monostatic Z-component data are also suitable for use to select background locations, which in turn can be used to level all of the 48 Tx/Receive (Rx) coil combination data in a manner similar to that used for background removal of cued target measurements.

### 3.1.3. Target Selection

Target selection using the TEMTADS dynamic data is performed using the traditional amplitude response metric using the mapped Z-component data described above. Alternately a dipole response filter approach or other advanced anomaly selection technique that uses a larger subset of the available data can be used.

#### 3.1.3.1. Response Amplitude Detection:

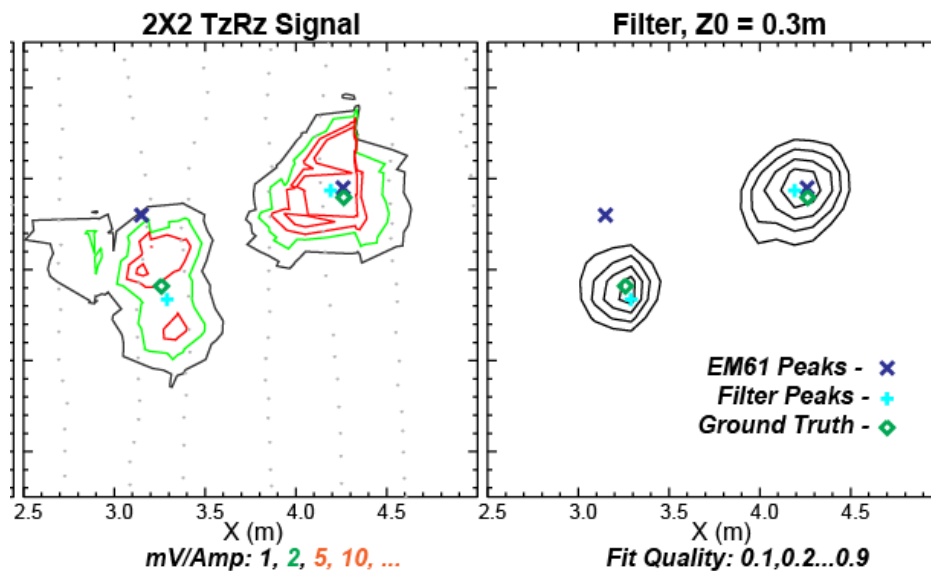
Traditional anomaly selection is based almost entirely on signal response amplitude. Using the TEMTADS dynamic survey monostatic Z-component response amplitude as a detection metric is essentially the same as using a Geonics EM61 response amplitude detection. After the data have been gridded, the Geosoft automatic grid peak detection algorithm is used to extract locations of all grid peaks that are above the project detection threshold. These target anomaly locations are reviewed by the project geophysicist and manual additions and deletions are made to this list. The final list is reviewed by the quality control (QC) geophysicist prior to finalization of the target list.

### 3.1.3.2. Dipole Response Filter Detection:

The 'dipole response filter' approach to anomaly detection makes use of the rich data set output of the advanced sensors. This target selection routine takes advantage of all the measured data – not just the monostatic Z component – by employing an automated dipole inversion routine to estimate the source locations. The process involves:

1. assuming a target's location (at every 10 centimeter [cm] spaced grid node across the site)
2. extracting data within a specified sensor footprint
3. inverting for dipole polarizations
4. extracting the 'goodness-of-fit parameter' as the detection metric

The 'goodness-of-fit' filter output is the squared correlation between the full multi-axis, multi-static TEMTADS data set and a dipole model fit to those data. This filter output is mapped in the same manner as the amplitude response and peaks in the detection metric indicate target locations as illustrated by Figure 2.



**Figure 2.** Data subset showing mapped response amplitude (left) and mapped filter response output (right) with ground truth information superimposed. Contour line values are provided in the legend.

Accordingly, target selection using the dipole filter fit coherence metric is accomplished in the same manner as for the amplitude response approach. After running the automatic peak detection routine, the target list will be reviewed and manual additions/deletions will be made.

### 3.2. Assessment of Quality Control of Dynamic Survey Data

During the course of a dynamic survey, QC measurements are performed on a daily basis to verify the operation of the sensor and associated components. These tests are comprised of function tests

(described in SOP 1) and transects along the instrument verification strip (IVS). The successful completion of these tests on a daily basis is required to validate the survey data collected on that day.

### **3.2.1. Function Test Measurement Processing**

Function test measurements (described in SOP 1) are performed prior to each sortie to confirm that all transmit and receive components of the TEMTADS sensor are operational. The data from each function test are assessed relative to the MQOs presented in Worksheet #22, compiled and presented in graphical form for review. Results that do not pass the MQOs are identified and the appropriate action specified in Worksheet #22 is taken.

### **3.2.2. Daily IVS Survey Processing**

Prior to the start and at the end of each day of data collection, measurements of the set of IVS targets are performed (described in SOP 2). These data are processed in the same manner as the production survey data with regard to positioning and background removal. The data from each IVS test are assessed relative to the MQOs presented in Worksheet #22, compiled and presented in graphical form for review. Results that do not pass the MQOs are identified and the appropriate action specified in Worksheet #22 (root cause analysis (RCA)/corrective action (CA) are taken. Depending upon the findings of the RCA, the survey data associated with the IVS MQO failure may need to be re-collected.

## **4. Data Management**

### **4.1. Data inputs**

The data inputs required for processing dynamic TEMTADS data are:

- a list of coordinates identifying the site boundaries.
- raw Dynamic TEMTADS data files.
- amplitude response minimum detection threshold (derived from the project-specific QAPP).

### **4.2. Data Outputs**

The data outputs of the processing of dynamic TEMTADS data are:

- QC reports summarizing daily QC measurement results
- mapped detection metric data (Z-component amplitude and dipole response coherence) in ASCII (x,y,z) format
- target anomaly list (identifier (ID), X, Y)
- letter report detailing processing approach including leveling and target selection procedures

## **5. Quality Control**

The Quality Control checklist presented as Attachment 1 to this SOP will be filled out and delivered as part of the reporting requirement for this SOP.

The MQOs for processing dynamic TEMTADS data are presented in Worksheet #22 of the project-specific QAPP. Performance relative to the MQOs will be assessed during the processing of the data. Dynamic TEMTADS data will not be used to select targets until these MQOs are met or until the project team agrees on modifications to these MQOs.

## 6. Reporting

Reporting of the activities associated with this SOP will consist of the following:

- digital Field notes
- data processing log detailing the following for each sortie (chronologically contiguous data collection set):
  - survey date
  - % invalid data with regard to transmit (Tx) current, GPS fix quality, IMU data quality, EMI response within range
  - standard quality control checks performance
    - correct coordinates for grids
    - coverage
    - line gaps
    - background response
    - dropouts
    - downline density
    - appropriate leveling
    - appropriate anomaly selection
  - associated Function Test filename
  - associate IVS Test filename(s)
  - area subset (grid ID)
- QC report summarizing daily QC results (Function tests and IVS tests)
- target List – final list of identified anomalies for delivered area subset
- final data archive (gdb or xyz format) for delivered area subset
- final grids of Z-component amplitude response for delivered area subset
- final grids of detection metric (if not amplitude response) for delivered area subset
- processing/data selection letter report

## SOP 5T

### Attachment 1 Dynamic TEMTADS Data Processing QC Checklist

This checklist is to be completed by the data processor or Project Geophysicist for every delivered data set (usually a contiguous subset of the project survey area).

QC Step	QC Process	Yes/No	Initial of Field or Project Geophysicist
1. Function Tests	Was the functionality of the TEMTADS EMI components verified for each sortie using function tests and did all function tests pass the MQO for this test?		
2. IVS Tests	Was the functionality of the TEMTADS system verified for each sortie using IVS tests and did all IVS tests pass the associated MQOs?		
3. Data Validity	Were invalid data for each sortie (with regard to Tx current, GPS fit quality, IMU data quality, and EMI response within range) identified and rejected?		
4. Coverage	Were gaps in data coverage due to down-line and across line sampling identified and accounted for (obstructions)?		
5. Background removal	Was the background model inspected prior to subtraction from the raw data and was the leveling reviewed by the QC Geophysicist?		
6. Target selection	Was the final target list reviewed by the data processor and the QC geophysicist?		
7. Reporting/deliverables	Were the following documents completed and delivered: <ul style="list-style-type: none"> <li>– Digital Field notes</li> <li>– Data processing log</li> <li>– Target List</li> <li>– Final data archive (gdb or xyz format)</li> <li>– Final grids</li> </ul>		

Data Processor: \_\_\_\_\_ Date: \_\_\_\_\_

Project Geophysicist: \_\_\_\_\_ Date: \_\_\_\_\_

## STANDARD OPERATING PROCEDURE 6

### Collect Static Background Measurements

---

#### 1. Purpose and Scope

The purpose of this Standard Operating procedure (SOP) is to identify the means and methods to be employed when selecting the positions for background measurements using an advanced digital geophysical mapping system and verifying the usability of the resulting background data. The observed signal in a cued measurement using advanced sensors is composed of 1) the EMI response of the buried target, 2) the self-signature of the sensor system, and 3) any response from the ambient environment in which the target is buried. The objective of taking background measurements is to independently measure the last two contributors to the overall EMI response. These “non-target” values can then be subtracted from the overall signal response to determine the signal response from only the unknown buried object being evaluated. For this to be successful the background measurements must be collected in an area without any buried targets and with a geology representative of that where the unknown items are located. They must also be taken throughout the survey day because environmental changes such as large changes in ambient temperature, significant changes in background moisture (morning dew evaporating, rain showers passing through, etc.), or significant changes to the sensor itself (cable replacement, new GPS antenna, etc.) will cause the sensor or environmental contribution to the background reading to change.

#### 2. Personnel, Equipment and Materials

This section describes the personnel, equipment and materials required to implement this SOP.

The following individuals will be involved in the collection of background data:

- Project Geophysicist
- QC Geophysicist
- Field Team Leader
- Data Processor

The qualifications of the personnel implementing this SOP are documented in the QAPP Worksheet #4, 7 & 8.

The following is a list of required equipment and materials:

- Geometrics MetalMapper or TEMTADS sensor coupled with a real-time kinematic Global Positioning System (RTK GPS) and orientation sensor

#### 3. Procedures and Guidelines

Background measurements will be recorded no less than every two hours throughout the survey day and at one or more geographic locations as required to document the EMI signatures of near-surface

soils present at the site. Background measurements involve positioning the sensor and collecting static measurements over a pre-identified set of background locations. In combination with SOPs for sensor assembly (SOP 1) and testing at the IVS (SOP 2), background data are collected that are used to correct the static data described in SOP 6.

Prior to cued data collection, the correct operation of the geophysical sensor and navigation and orientation systems must be verified at the Instrument Verification Strip (IVS) as described in SOP 2. This will be verified by completion of the QC checklist attached to SOP 2.

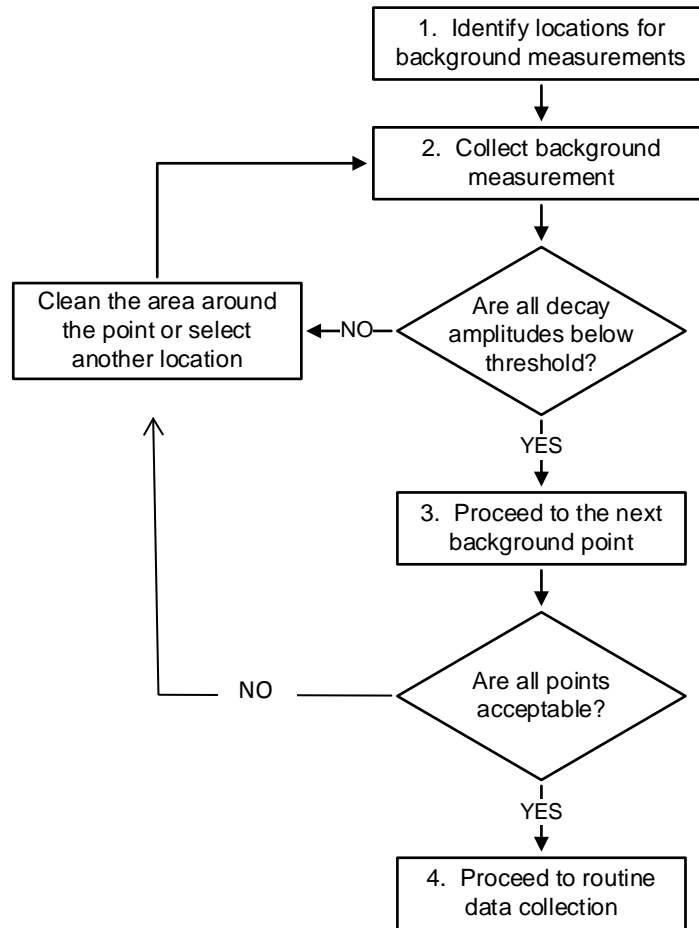
### **3.1. Choose Locations for the Background Measurements and Verify Their Suitability**

One or more locations for background measurements will be planned at each site. The number and location of the background measurements will be influenced by the following considerations:

- The background measurements should be collected at locations that are similar to that of the production survey area with regard to geophysical noise, terrain, geology, and vegetation. If these factors change appreciably, additional background measurements, taken at a more representative location, will be required.
- The background measurements should be collected at locations devoid of buried metal objects. If a suitable object free area cannot be identified, attempts should be made to create a “clear” 2-m square area by surveying and removing all metal objects. Once cleaned, the background measurements should be re-collected in the “clear” area.
- For efficiency, background measurements should be collected in areas that are close to the survey area(s) to minimize travel time.

Once an adequate number of background locations have been identified, an initial measurement should be collected over each of the background locations in turn as illustrated in Figure 1 on the next page.





**Figure 1.** Choosing and verifying locations for background measurements

1. Initial locations for the background measurement are chosen most easily by referring to the dynamic survey data. These data can be used to guide the geophysicist to suitable locations that satisfy the considerations noted above.
2. Once an adequate number of initial locations have been identified an initial measurement should be collected over each of the background locations as follows:
  - a. Center the MetalMapper or TEMTADS over the location chosen as a background point. Mark the corners of the sensor with non-metallic pin flags to allow this same location to be found again for future background readings.
  - b. Record the stationary geophysical data at this location and verify that the signal amplitudes for all decays measured are below the threshold chosen for this project. If higher amplitude decays are observed, the location should be inspected and any metal contamination found should be removed. Alternatively, another nearby location can be chosen.
3. Each background location is verified by comparing a set of 5 measurements taken at the intended location: one measurement at the location and one more with the sensor offset by ½

sensor spacing in each cardinal direction. Next, the forward model of the most challenging target of interest / depth scenario (e.g. 37mm at 30cm depth) is added to the center background measurement and the background is verified by separately subtracting each of the 4 offset backgrounds and performing a library match to the target of interest. The background location is considered valid if the library match from all 4 offsets exceeds 0.9. These images will be saved and presented in a background summary report.

4. Continue this process at each of the chosen locations until their suitability for background measurements has been verified.
5. Once this process is complete, these measurements will serve as baseline values for succeeding background measurements at each point.

### **3.2. Collect Background Measurements throughout the Survey Day**

Background measurements should be collected with a minimum spacing of two hours throughout the survey day. Additional background measurements can be taken if the Project Geophysicist or Field Team Leader determines that changes made to the sensor or natural environmental changes may have caused the sensor or environmental contribution to the background reading to change. Careful field notes should be made to document the reasons for extra background readings to guide the Data Processor in choosing the correct background for each cued data set.

The procedure for taking background measurements is as follows:

1. Return the sensor to one of the previously verified background measurement locations taking care to position the sensor as closely as possible to the initial location and orientation.
2. Collect a background measurement.
3. Compare the Background Amplitude Metric to the original value at this location. If the two values differ by more than a factor of five, repeat the measurement.
4. If the deviations persist, document the environmental changes that may have led to this deviation in the field notes and record approval by the Project Geophysicist before proceeding.

## **4. Data Management**

The following sections describe the data that is needed to perform this SOP and the resulting data.

### **4.1. Input Data Required**

In initial list of suitable background locations, identified from the survey data, is required to begin this SOP. After the locations have been verified, they become the final background location list.

### **4.2. Output Data**

The background data collected at each background location will be saved in the project database. Also, the QC checklist in Attachments 1 through 3 of this SOP will be completed, signed, and filed.

## 5. Quality Control

This procedure is performed throughout the project and, therefore, has Preparatory, Initial and Follow-on QC checks. Performance of the required QC checks will be documented on the Preparatory, Initial and Follow-on QC checklists in Attachments 1 -3 to this SOP as follows:

- The Preparatory Checklist (Attachment 1) will be completed to document the identification of the background locations.
- The Initial Checklist (Attachment 2) will be completed to document the initial background readings at each selected background location.

This procedure ensures that the MetalMapper is working properly and that the field geophysical team is collecting data of adequate quality. Therefore, for routine background measurements, this procedure requires only Follow-on QC inspections which are documented through the following steps:

1. The operating software automatically logs the responsible geophysicist's identification in each data file. By logging the background data, and thereby taking responsibility for it, the geophysicist logging the data is certifying that they have complied with the requirements of this SOP.
2. The QC Geophysicist will observe background data collection each morning and afternoon of data collection activities and document this in the Daily Geophysics QC Report.
3. Achievement of the background collection MQOs will be documented by the Field or Project Geophysicist and verified by the QC Geophysicist in the Geophysics Daily QC Report.
4. During review of each background measurement, the Data Processor will overlay the measured decays from all measurements at that location to observe any variation. Should variations be observed that are not the result of changing environmental conditions documented by the field crew, a comprehensive root-cause analysis will be performed and a corrective action determined.

The measurement quality objectives (MQOs) for background measurements are presented in Worksheet #22 of the QAPP. Measured backgrounds will not be used to correct field data until these MQOs are met or until the project team agrees on modifications to these MQOs.

## 6. Reporting

This procedure will be documented through the completion of the Preparatory, Initial and Follow-on QC Checklists in Attachments 1 through 3 by the Field or Project Geophysicists. The completed checklists will be used to document the selection and preparation of the background areas (Preparatory Inspection Checklist in Attachment 1), the initial background readings taken at each selected area (Initial Inspection Checklist in Attachment 2), and the routine four-times-daily (at a minimum) background readings taken during the production survey (Follow-on Checklist in Attachment 3). The QC Geophysicist will observe the background readings being collected and will document completion of all checklists in the Geophysics Daily QC Report and copies of the completed checklists will be attached to the report.

## SOP 6

### Attachment 1 Preparatory Background Collection QC Checklist

This checklist is to be completed by the Field or Project Geophysicist during selection and preparation of the background areas. Successful completion of this process will be verified by the QC Geophysicist in the Daily Geophysics QC Report.

QC Step	QC Process	Yes/No	Initial of Field or Project Geophysicist
1. Qualifications	Are the same geophysical personnel being used as in SOP 1? If not, have the qualifications of the new personnel been verified?		
2. Background area selection	Do the selected background areas have similar geophysical noise, terrain, geology and vegetation as the production survey area they represent i/a/w this SOP?		
3. Background area selection and preparation	Are the selected background areas devoid of buried metal objects or has a 2-m square area been "cleaned" i/a/w this SOP?		
4. Background area selection	Are the selected background areas sufficiently close to the production area to minimize travel i/a/w this SOP?		

Field Geophysicist: \_\_\_\_\_ Date: \_\_\_\_\_

Project Geophysicist: \_\_\_\_\_ Date: \_\_\_\_\_

Data Processor: \_\_\_\_\_ Date: \_\_\_\_\_

## SOP 6

### Attachment 2 Initial Background Data Collection QC Checklist

This checklist is to be completed by the Field or Project Geophysicist during the initial data collection at each background area. Successful completion of this process will be observed and verified by the QC Geophysicist in the Daily Geophysics QC Report.

QC Step	QC Process and Guidance Reference	Yes/ No	Initial of Field or Project Geophysicist
1. Qualifications	Are the same geophysical personnel being used as in SOP 1? If not, have the qualifications of the new been verified?		
2. Preparation	Has the SOP 1 Preparatory Checklist been successfully completed?		
3. Preparation	Have the instrument start-up procedures and pre-operation checklist from SOP 1 (Attachment 1) been successfully completed?		
4. Data collection	Is the instrument properly centered on the background location and are the corners of the sensor marked with non-metallic pin flags i/a/w this SOP?		
5. Data collection	Was the background data recorded and the signal amplitude verified to be below the selected threshold i/a/w this SOP?		
6. Data collection	Is background data recorded for each background location i/a/w this SOP?		
7. Data analysis	Are the background readings for each area recorded i/a/w this SOP? Background ID _____ Reading _____ Background ID _____ Reading _____ Background ID _____ Reading _____ Background ID _____ Reading _____ Background ID _____ Reading _____		
8. MQO Documentation	Have the appropriate MQOs from Worksheet #22 been achieved?		

Field Geophysicist: \_\_\_\_\_ Date: \_\_\_\_\_

Project Geophysicist: \_\_\_\_\_ Date: \_\_\_\_\_

Data Processor: \_\_\_\_\_ Date: \_\_\_\_\_

## SOP 6

### Attachment 3 Follow-on Background Data Collection QC Checklist

This checklist is to be completed by the QC Geophysicist daily. It should be noted that the identity of the geophysicist responsible for logging each anomaly is recorded in the anomaly data. Every time the Field Geophysicist logs cued background data they are certifying that they have complied with the requirements of this SOP. The QC Geophysicist will observe the background collection process at least twice per day and will document the successful completion of this checklist in the Daily Geophysics QC Report.

QC Step	QC Process	Yes/No	Initial of QC Geophysicist
1. Qualifications	Are the same geophysical personnel being used? If not, have the qualifications of the new personnel been verified?		
2. Preparation	Has the start-up and IVS QC checklist from SOP 2 been successfully completed?		
3. A.M. Field Observation	Was the a.m. field observation performed? Time: _____ Background #s: _____		
4. P.M. Field Observation	Was the p.m. field observation performed? Time: _____ Background #s: _____		
5. Field Documentation	Did the QC Geophysicist review the day's data collection with the Field Geophysicist and review the Field Geophysicist's notebook? Were any technical issues noted?		
6. MQO Documentation	Have the appropriate MQOs from Worksheet #22 been achieved?		

QC Geophysicist: \_\_\_\_\_ Date: \_\_\_\_\_

## STANDARD OPERATING PROCEDURE 7

### Collect Cued Target Measurements

---

#### 1. Purpose and Scope

The purpose of this Standard Operating procedure (SOP) is to identify the means and methods to be employed when collecting cued measurements using a MetalMapper or TEMTADS advanced electromagnetic induction (EMI) sensor for target classification. Cued data collection involves navigating the sensor to the precise anomaly location, collecting static, advanced electromagnetic sensor data at this location, and verification of the integrity and validity of the collected data. Verification includes using the sensor data to derive an estimate of the target position relative to the center of the sensor. If this position estimate falls outside a predetermined threshold, the sensor will be repositioned and a second data collection event will be performed.

#### 2. Personnel, Equipment and Materials

This section describes the personnel, equipment and materials required to implement this SOP.

The following individuals will be involved in the collection of cued target data:

- Project Geophysicist
- QC Geophysicist
- Field Team Leader
- Data Processor

The qualifications of the personnel implementing this SOP are documented in the QAPP Worksheet #4, 7 & 8.

The following is a list of required equipment and materials:

- Geometrics MetalMapper or TEMTADS sensor coupled with a real-time kinematic Global Positioning System (RTK GPS) and orientation sensor

#### 3. Procedures and Guidelines

Cued investigation for target classification involves positioning the sensor and collecting static measurements over a pre-identified set of anomalies. In combination with SOPs for sensor assembly (SOP 1), testing at the IVS (SOP 2) and collecting background measurements (SOP 6), a set of static data measurements are collected using the MetalMapper or TEMTADS over each anomaly. At each anomaly the data acquisition will be performed using the steps shown in Figure 1.

Prior to cued data collection, the correct operation of the geophysical sensor and navigation and orientation systems must be verified at the Instrument Verification Strip (IVS) as described in SOP 2. This will be verified by completion of the QC checklist attached to SOP 2.

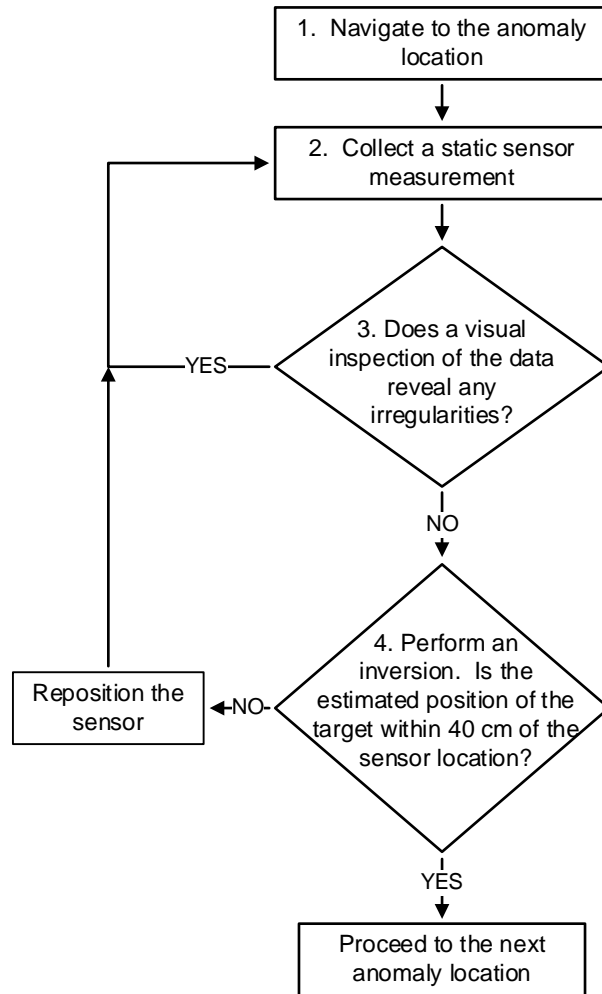


Figure 1. Procedure to collect a cued target measurement

The following is a description of each of the steps shown above:

1. **Navigate to the Anomaly Location.** Navigation to the anomaly location may be performed visually or through the use of the RTK GPS positioning system. Visual navigation requires marking the anomalies (usually with survey pin flags) in advance. Although some sensors may have the ability to direct the operator to an anomaly location based upon the geophysical signal received, the first measurement will be taken at the predetermined anomaly location as indicated by visual alignment with the pin flag or RTK GPS position relative to the predetermined position.

To implement this step the sensor will be transported to the anomaly location and the center of the sensor precisely positioned (within 5-cm) over the provided anomaly location.



2. **Collect a set of static sensor measurements.** Initiate the collection of a set of measurements. During this measurement, care will be taken to ensure that the sensor does not move, and all external sources of EM signals (i.e. metal) are kept away from the sensor.

Any metal associated with the sensor and deployment mechanism (e.g. console, support structures) that cannot be reasonably distanced from the sensor must be kept in the same physical relation with the sensor as was maintained during background measurements.

3. **Verify the integrity and quality of the collected data.** Immediately after data acquisition, the integrity and quality of the data will be verified by the operator by inspection of the MetalMapper data collection screen to ensure that:

- the data acquisition cycle completed properly.
- the transmit current for each transmitter was within an acceptable range (6 – 8 A).
- the decay curves measured by each receiver coil appear reasonable (i.e. – not ‘flat-lined’).

4. **Perform a field inversion.** Valid inversion results require that the target is located within a 40-cm of the center of the sensor. The initial target horizontal position may be significantly offset from the center of the sensor for the following reasons:

- positioning errors in the initial detection survey
- imprecision in the derivation of the anomaly position from the detection survey data set
- imprecision in the reacquisition and flagging of the anomaly
- imprecision in positioning the sensor
- the presence of multiple anomaly sources in relatively close proximity

This step includes performance of an in-field inversion and inspection of the results to verify that the estimated horizontal target location is within the 40-cm of center specification. After initiating the in-field inversion algorithm an estimate of the target location relative to the center of the sensor is provided. If the offset is greater than 40 cm, position the sensor over the target location estimate provided by the in-field inversion (visually or using the RTK GPS data) and repeat Steps 1 and 2.

This recollection should only be performed once. Assuming the repositioning was performed accurately, if the subsequent position estimate is still > 40cm from the sensor center the cause is likely to be multiple anomaly sources and additional data collection and data analysis may be required after further analysis by the QC geophysicist.

## 4. Data Management

The following sections describe the data that is needed to perform this SOP and the resulting data.

### 4.1. Input Data Required

An anomaly list consisting of anomaly IDs and UTM Northing and Easting coordinates in meters.

## 4.2. Output Data

The output data from this SOP will consist of one raw sensor data file (.tem or .hdf5) per anomaly interrogated. These data files will be transferred daily (or more often as dictated by site procedures) to the data analyst.

## 5. Quality Control

The Preparatory and Initial QC checks for this SOP are performed during the implementation of SOP 2, “Test Sensor and System at the IVS”. SOP 2 ensures that the MetalMapper is working properly and that the field geophysical team is collecting data of adequate quality. Therefore, this procedure requires only Follow-on QC inspections which are documented through the following steps:

- The operating software automatically logs the responsible geophysicist’s identification in each data file. By logging the data, and thereby taking responsibility for it, the geophysicist logging the data is certifying that they have complied with the requirements of this SOP.
- The QC Geophysicist will observe data collection each morning and afternoon of data collection activities and document this in the Daily Geophysics QC Report.

Daily data packages, containing the geophysical data from that day, will be reviewed by the QC Geophysicist to ensure that the Measurement Quality Objectives (MQOs) are being achieved. A comprehensive root-cause analysis will be performed and a corrective action will be determined if the QC Geophysicist determines that the MQOs are not being met or if a trend toward the MQO limits is observed.

The measurement quality objectives (MQOs) for cued target measurements are presented in Worksheet #22 of the QAPP. Cued data will not be used to classify targets until these MQOs are met or until the project team agrees on modifications to these MQOs.

## 6. Reporting

This SOP will be documented through the completion of the Follow-on QC Checklist in Attachment 1. Since the Field Team Leader is certifying their compliance with this SOP every time they log data the Follow-on Checklist for this SOP will be completed by the QC Geophysicist and will document the successful completion of equipment start-up and the IVS (SOP 2) and the twice-daily (a.m. and p.m.) observation of data collection by the QC Geophysicist.

The Field Geophysicist will also maintain a field notebook and the QC Geophysicist will review this notebook daily to note issues that potentially affect quality. The completion of all checklists will be noted by the QC Geophysicist in the Daily Geophysics QC Report and a copy of the completed checklists will be attached to the report.

## SOP 7

### Attachment 1 Cued Geophysical Data Collection Follow-on QC Checklist

This checklist is to be completed by the QC Geophysicist daily. It should be noted that the identity of the geophysicist responsible for logging each anomaly is recorded in the anomaly data. Every time the Field Geophysicist logs cued anomaly data they are certifying that they have complied with the requirements of this SOP. The QC Geophysicist will observe the data collection process at least twice per day and will document the successful completion of this checklist in the Daily Geophysics QC Report.

QC Step	QC Process	Yes/No	Initial of QC Geophysicist
1. Qualifications	Are the same geophysical personnel being used? If not, have the qualifications of the new personnel been verified?		
2. Preparation	Has the start-up and IVS QC checklist from SOP 2 been successfully completed?		
3. A.M. Field Observation	Was the a.m. field observation performed? Time: _____ Anomaly #s: _____		
4. P.M. Field Observation	Was the p.m. field observation performed? Time: _____ Anomaly #s: _____		
5. Field Documentation	Did the QC Geophysicist review the day's data collection with the Field Geophysicist and review the Field Geophysicist's notebook? Were any technical issues noted?		
6. MQO Documentation	Have the appropriate MQOs from Worksheet #22 been achieved?		

QC Geophysicist: \_\_\_\_\_ Date: \_\_\_\_\_

## STANDARD OPERATING PROCEDURE 8

### Process Cued METALMAPPER or TEMTADS Data

---

#### 1. Purpose and Scope

The purpose of this Standard Operating procedure (SOP) is to identify the means and methods to be employed when processing cued measurements collected using a MetalMapper or TEMTADS advanced electromagnetic induction (EMI) sensor for target classification. Cued surveys include the collection of cued data over predetermined target locations and background locations. Cued measurements are also performed over instrument verification strip (IVS) targets for quality control (QC) purposes. This SOP details the steps required to verify the quality of these measurements, process these measurements to derive features related to the physical characteristic of the target, and use these features to classify the targets.

#### 2. Personnel, Equipment and Materials

This section describes the personnel and equipment required to implement this SOP.

The following individuals will be involved in the processing of cued MetalMapper or TEMTADS data for advanced analysis:

- Project Geophysicist
- QC Geophysicist
- Field Team Leader
- Data Processor

The qualifications of the personnel implementing this SOP are documented in the QAPP Worksheet #4, 7 & 8.

The only required equipment is a data processing computer suitable for and equipped to run the processes provided in the UXA-advanced module of Geosoft's Oasis Montaj geophysical processing environment.

#### 3. Procedures and Guidelines

##### 3.1. Data Import/Initial QC

The raw \*.TEM data are converted to ASCII \*.csv files using:

- a purpose built software utility (Convert\_TEMTADS) supplied by the Naval Research Lab (NRL) or
- the EM3D Plot export utility

The data are then imported into Geosoft's UXAnalyze-Advanced (UXA) purpose built processing environment. This process results in three separate databases that contain:

- target anomaly measurement data

- background measurement data
- target list

The cued measurements from the TEMTADS go into the target anomaly or background databases and the Target list is where the derived feature and classification information for each target are summarized.

Once imported the data are inspected and assessed against the measurement quality objectives (MQOs) provided in QAPP Worksheet #22 for:

- Transmit (Tx) current within limits
- Global positioning system (GPS) fit quality
- valid inertial measurement unit (IMU) data
- EMI response signal not saturated

### **3.2. Background Corrections**

Background corrections are used to remove the self-signature of the advanced sensor system and the soil response from the measured anomaly data. Background measurements are taken at locations selected from the detection survey data set. Prior to utilizing these locations for background measurements, they need to be verified to be devoid of metal. Additionally each background measurement needs to be verified as suitable prior to using it for background correction of the target measurement data.

#### **3.2.1. Background Measurement Verification**

Individual background measurements must be verified prior to their use for background corrections. Background measurements will be compared to the initial background verification measurement at the same position and verified as qualitatively similar. These images will be saved and presented in a background summary report. Invalid measurements will be removed from background database to ensure that they are not used.

#### **3.2.2. Background Corrections**

Background corrections are applied using a purpose built tool in UXA that automatically finds the closest background (chronologically and spatially) and will only apply the background corrections that were collected within a preset time limit relative to the target measurement. This preset time limit will be set to 2 hours. The background corrected data are stored in the channel "UXA\_Data\_Lev". This is the data channel that is submitted to the inversion processes to derive target features. This data channel will not be populated for those target measurements that do not have a suitable background measurement within the 2 hour time limit.

### 3.3. Function Test Measurements

Function test measurements (described in SOP 1) are performed in conjunction with the background measurements to confirm that all transmit and receive components of the TEMTADS sensor are operational. These data are background corrected, then the monostatic components are compared to a benchmark set of values to confirm that all components are fully operational. This comparison is performed in the field and the results are provided in real time. The data processor should perform the same background corrections and log the results for QC/quality assurance (QA) purposes.

### 3.4. Target Feature Estimation

After background corrections are applied, intrinsic and extrinsic features are estimated for the target anomalies as well as the daily QC measurements collected at the IVS.

Single target and multi-target inversion routines in UXA-Advanced are used to determine the parameters of a target (single-target inversion), or constellations of targets (multi-target inversion), that would produce responses that closely match the observed responses. These parameters include extrinsic parameters (location and orientation) as well as the intrinsic parameters (principal axis polarizabilities) related to the object size shape and composition. The intrinsic parameters, otherwise known as betas ( $\beta$ ) are used for classification.

As the names suggest, the single-target inversion solves for a single target and the multi-target inversion posits multiple targets. The multi-source solver not only presupposes multiple sources, it will also produce a number of candidate 'realizations' of targets. Each candidate realization proposes a configuration of targets whose modeled response reasonably fits the observed data. For example, one candidate realization may have three targets, while a second candidate realization for the same measurement may have two or four targets. This process reflects the fact that, with an unknown number of potential targets of difference sizes and shapes, a number of different models can closely match the observed data. A separate fit coherence value is derived for each candidate realization as well as for the single solver.

Model results will only be used for classification if they pass the MQOs identified to confirm that they support classification (QAPP Worksheet #22).

### 3.5. Daily IVS Survey

Prior to the start and at the end of each day of data collection, measurements of the set of IVS targets are performed (described in SOP 2). These measurements are processed as described above and the derived features are assessed against the MQOs presented in WS #22. These results are documented and summarized in a QC report to be generated for each delivered prioritized list.

### 3.6. Classification

Classification of targets will be based upon objective, numeric criteria. Using these criteria, a prioritized list is created with high likelihood target of interest (TOI) placed at the top of the dig list (just after digs

classified as “training data” and “can’t analyze”) and high likelihood non-TOI placed at the bottom of the list. The primary method for classification will be library matching, supplemented by cluster analysis and feature space analysis.

### **3.6.1. Site Specific Munitions Library**

A site specific library of  $\beta$ s for candidate munitions items identified in the conceptual site model (CSM) will be used for classification. Entries in existing libraries will be confirmed as representative (i.e. the same caliber, model and configuration) of the munitions items presented in the table by a qualified unexploded ordnance (UXO) Technician. Intrinsic parameters for items listed in the CSM not confirmed to be in the existing library will be derived from test measurements prior to the start of the classification process if the items are available for test or the closest available item in size and shape will be used as a surrogate.

### **3.6.2. Library Matching**

Classification is based primarily on the goodness of fit metric (values from 0.0 to 1.0) generated by UXA during a comparison of the  $\beta$  values estimated for each surveyed target and the  $\beta$  values in the munitions library developed for the project. This comparison is performed via the library match utility in UXA. The goodness of fit metric is a measure of the fit correlation between a target and the library entry that best fits that target, with higher values indicating a better fit between the target and the corresponding item in the library. The library fit analysis matches the following four combinations of  $\beta$ s to those of the candidate library TOIs:

- $\beta_1, \beta_1/\beta_2, \beta_1/\beta_3$
- $\beta_1, \beta_1/\beta_2$
- $\beta_1/\beta_2, \beta_1/\beta_3$
- $\beta_1$

The confidence metrics for each fit combination are averaged to derive a ‘decision metric’.

This library matching process is performed for each single-solver model and every target in each of the multi-source solver candidate realization models. For each flag position, the best library fit from the single-solver and multi-solver targets is used as the decision metric. This decision metric is used to rank and classify the target list. Values below the analysts threshold (nominally 0.8) are considered non-TOI.

A set of training digs are identified by the analyst. The intrusive investigation results of these digs as well as decision metrics derived for other known TOI (IVS and seed items) are used to finalize the analyst threshold.

### **3.6.3. Cluster Analysis/Feature space Analysis**

Cluster analyses are performed whereby the clusters of anomalies with similar  $\beta$  signatures are identified using the self match utility in UXA. For each identified cluster, a representative sample is intrusively investigated as part of the training data. If the intrusive investigation identifies a hazardous

item, a representative signature is placed in the site specific library and the matching process will be repeated to ensure that all similar items are classified as TOI.

Individual items that do not match any library items but have  $\beta$ s that indicate a large, axially symmetric, thick-walled object are identified and investigated as part of the training data and added to the library if they are identified as TOI.

## 4. Data Management

### 4.1. Data inputs

The data inputs required for performing a cued advanced analysis data processing are:

- a list of target anomalies including identifier (ID) and position (X, Y)
- a list of Background locations (ID, X, Y)
- a list of IVS locations (ID, X, Y)
- MetalMapper or TEMTADS measurement data including those for target anomalies, daily IVS, backgrounds, and function tests
- digital field notes for all data collection activities
- site specific library signatures and/or test stand measurements of intended site specific library items

### 4.2. Data Outputs

The data outputs of the cued advanced analysis data processing for each delivered survey unit (contiguous subset of the survey site) are:

- QC report including documenting performance relative to QAPP Worksheet #22 for:
  - IVS results
  - function test results
  - background measurements
  - target anomaly measurements
- prioritized target list
- target classification report
- revised validation plan
- target measurement data, background measurement data, and target feature databases
- supporting documents for classification (PDF images)

## 5. Quality Control

The QC checklist presented as Attachment 1 to this SOP will be filled out and delivered as part of the reporting requirement for this SOP.



The measurement quality objectives (MQOs) for cued target measurements are presented in Worksheet #22 of the QAPP. Performance relative to the MQOs will be assessed during the processing of the collected data. Cued data will not be used to classify targets until these MQOs are met or until the project team agrees on modifications to these MQOs.

## 6. Reporting

Reporting of the activities associated with this SOP will consist of:

- a QC Report detailing the system performance against the MQOs identified on QAPP Worksheet #22 (including MQOs for daily IVS and Function Test performance as well as for individual measurement metrics).
- a Classification Report detailing specific approach to classification including final library make-up, cut-off threshold, cluster analysis approach and results, and feature space analysis approach and results.

## SOP 8

### Attachment 1 Cued Geophysical Data Processing QC Checklist

This checklist is to be completed by the Field or Project Geophysicist every time cued TEMTADS data are collected.

QC Step	QC Process	Yes/N o	Initial of Field or Project Geophysicist
1. Background Locations	Were background locations verified to be free of localized sources?		
2. Background Measurements	Were background measurements verified to be within the defined limits?		
3. Function Tests	Was the functionality of the TEMTADS EMI components verified for each sortie using function tests collected on the same day and did all associated function tests pass the MQO for this test?		
4. IVS Tests	Was the functionality of the TEMTADS system verified for each measurement using IVS tests collected on the same day, and did all associated IVS tests pass the MQOs?		
5. Sensor Navigation	If GPS data are available for the target data collected, was valid data collected with the sensor positioned over the initial detected anomaly location with any exceptions noted in the processing notes?		
6. Cued Measurements	For each cued measurement used for classification (including background and IVS measurements), were the MQOs with regard to transmit current, receiver decay data met?		
7. Cued measurements	Do the derived models for each classified anomaly fit the observed data with a fit coherence that meets the MQO with exceptions added to the dig list as can't analyze (dig)?		
8. Cued Measurements	Do all targets classified as non-TOI have a fit position offset from the center of the array that meets the MQO?		
9. Reporting	Does the classification report describe the classification approach and identify the decision thresholds used to place an item on the non-TOI list?		

Data Processor \_\_\_\_\_ Date: \_\_\_\_\_

Project Geophysicist: \_\_\_\_\_ Date: \_\_\_\_\_

QC Geophysicist: \_\_\_\_\_ Date: \_\_\_\_\_

## STANDARD OPERATING PROCEDURE 9

### Verify Recovered Objects Are Compatible With Predictions

---

#### 1. Purpose and Scope

The purpose of this Standard Operating procedure (SOP) is to identify the means and methods to be employed when comparing the results of an intrusive investigation against the target parameters resulting from analysis of advanced sensor data.

#### 2. Personnel, Equipment and Materials

This section describes the personnel, equipment and materials required to implement this SOP.

The following individuals will be involved in background correction:

- Project Geophysicist
- QC Geophysicist

The qualifications of the personnel implementing this SOP are documented in the QAPP Worksheet #4, 7 & 8.

The following is a list of required equipment and materials:

- Oasis montaj with the UX-Analyze module activated
- results of the intrusive investigation to include recovery depths, photographs and descriptions

#### 3. Procedures and Guidelines

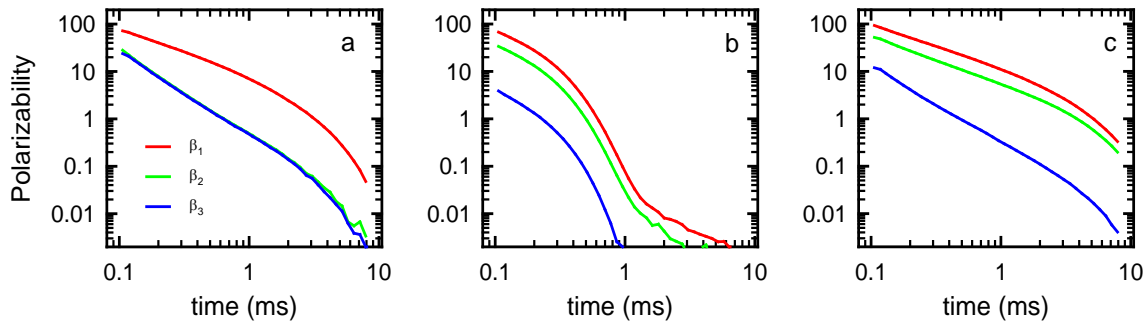
Each item recovered during the intrusive investigation of an anomaly should be compared to the results of the data analysis. Specific parameters to compare include burial depth, rough size, and item shape. Any significant deviations will require a re-examination of the anomaly and/or a re-analysis of the advanced sensor data.

##### 3.1. Compare Recovered Item(s) Against Predictions

In the case where only a single item is predicted to be the source of the anomaly, this comparison is relatively straightforward.

1. Compare predicted depth to actual burial depth. These should agree to within 10 cm.
2. Compare recovered item size to predicted size band. The project database in Oasis montaj will contain a predicted size for the item within three bands. Items defined as small will be the size of a 37-mm projectile and smaller, items defined as medium will be larger than a 37-mm projectile and smaller than a 105-mm projectile, and items defined as large will be the size of a 105-mm projectile and larger.
3. Compare the shape of the recovered item to the predicted shape. The predicted shape is inferred from the polarizability decay curves in the project database. Three examples of

symmetric (or near-symmetric) items are shown in Figure 1. If all three curves are different, then the object is predicted to be non-symmetric.



**Figure 1.** Examples of the polarizability decay curves for a variety of symmetric (or near-symmetric) objects. The curves in plot (a) depict a cylindrical object with one large response and two smaller, but equal responses. In addition, the polarizabilities decay slowly indicating a thick-walled object. The curves in (b) result from a plate-like object with two large and nearly equal, responses and one smaller response. These polarizabilities decay quickly indicating a thin-walled object. The object in plot (c) is also plate-like but thicker walled as indicated by the slowly decaying polarizabilities.

If the analysis indicates the anomaly results from multiple items, then a comparison will be required for each item recovered.

### 3.2. Resolution of a Mismatch

There are two common causes for a mismatch between the recovered object and the analysis predictions. The resolution of these cases is straightforward.

1. A small item is recovered from a shallow depth when the prediction is for a larger item more deeply buried. This often results from a failure of the intrusive crew to clear the hole after recovering a shallow frag item.
2. A small item (or no item) is recovered when the prediction is for a very deeply buried large item. This often results when the anomaly resulted from geologic interference. In attempting to reproduce the measured anomaly, the inversion routine is driven toward a very deep large anomaly.

Any other mismatch between prediction and observations will require an examination of the anomaly location or the analysis or both.

## 4. Data Management

The following sections describe the data that is needed to perform this SOP.

### 4.1. Input Data Required

The analysis predictions for depth, size, and shape are contained in the project database in Oasis montaj. The parameters of the recovered items are contained in the intrusive results file.

#### **4.2. Output Data**

The resolution of any mismatches between the recovered items and analysis predictions will be documented in an Analysis Verification Report to be submitted by the Project Geophysicist.

#### **5. Quality Control**

QC consists of performing the inspections on the Recovered Object Verification Checklist that is included as Attachment 1 to this SOP. This checklist will be completed by the QC Geophysicist and will be observed by the Project geophysicist who will document the implementation of this SOP in the Geophysics Daily QC Report.

The measurement quality objectives (MQOs) are presented in Worksheet #22 of the QAPP.

#### **6. Reporting**

Achievement of the Recovered Object Verification MQOs (see QAPP Worksheet # 22) will be documented by the QC Geophysicist by completion of the QC Checklist in Attachment 1 to this SOP.

## SOP 9

### Attachment 1 Follow-on QC Checklist for Recovered Item Verification

This checklist is to be completed by the QC Geophysicist for a series of recovered items.

Series of anomalies covered by this verification: From \_\_\_\_\_ To \_\_\_\_\_

Date: \_\_\_\_\_ Time: \_\_\_\_\_

QC Step	QC Process	Yes/No	Initial of Data Processor
1. Qualifications	Is the same QC Geophysicist being used? If not, has the qualifications of the new personnel been verified?		
2. Recovered object comparison	Did the QC Geophysicist compare each recovered item to the analysis predictions i/a/w this SOP?		
3. Resolution of mismatches	Was each mismatch successfully resolved (Section 3.2) and the resolution documented in a verification report i/a/w this SOP?		
4. MQO Documentation	Have the appropriate MQOs from Worksheet #22 been achieved?		

QC Geophysicist: \_\_\_\_\_ Date: \_\_\_\_\_

Project Geophysicist: \_\_\_\_\_ Date: \_\_\_\_\_

## STANDARD OPERATING PROCEDURE 10

### Validate Classification Process

---

#### 1. Purpose and Scope

The purpose of this Standard Operating procedure (SOP) is to identify the means and methods to be employed when validating the classification process at the completion of a munitions response. The items dug as TOI have validated the ability of the analyst to correctly classify UXO. This procedure is intended to validate the remaining question: was the analyst able to classify non-TOI correctly. To accomplish this validation, the site team will randomly select a number of anomalies classified as due to non-TOI. The analyst will provide the rationale for classifying these items as non-TOI. The items will be excavated and compared to this rationale.

#### 2. Personnel, Equipment and Materials

This section describes the personnel, equipment and materials required to implement this SOP.

The following individuals will be involved in background correction:

- Project Geophysicist
- QC Geophysicist
- Data Analyst

The qualifications of the personnel implementing this SOP are documented in the QAPP Worksheet #4, 7 & 8.

The following is a list of required equipment and materials:

- Oasis montaj with the UX-Analyze module activated
- results of the intrusive investigation for the validation items to include recovery depths, photographs and descriptions

#### 3. Procedures and Guidelines

The site team will choose a number of items (to be specified in Worksheet # 22 of the QAPP) for validation digs. In many cases, these items will be chosen randomly from the list of anomalies classified as non-TOI. It is possible that some of these validation items may be chosen based on particular characteristics of the item (e.g. a large “cluster” of items with similar polarizabilities that have not been investigated). This list will be provided to the analyst and intrusive team.

##### 3.1. Provide Rationale for Classification Decision

For each item on the validation list, the analyst will provide a brief rationale for the classification decision. In many cases, this will be a simple statement such as “item too small to be TOI,” “thin-walled

plate like object,” or “item recognized as a baseplate.” If a more detailed narrative is required, the analyst will provide it.

### **3.2. Excavate the Anomaly**

In parallel with the analyst’s work, the intrusive team will return to the listed anomalies and excavate them using standard procedures. The excavated items should be saved for examination by the QC geophysicist. If this is not possible, a series of photographs should be recorded.

### **3.3. Compare Excavated Item to Prediction**

Each excavated item will be compared by the QC geophysicist to the prediction generated by the analyst. Each recovered item should qualitatively support the rationale provided for the classification decision. For a single-source inversion this comparison is straightforward. For a multi-source inversion with several realizations, the comparison may be more involved but the principle remains the same.

In the unlikely event a TOI is recovered during this validation effort, all work should stop and the site manager notified of this serious systemic failure. Otherwise, the QC Geophysicist will prepare a Validation Report documenting the analyst’s predictions and the actual recoveries from the intrusive investigation.

## **4. Data Management**

The following sections describe the data that is needed to perform this SOP.

### **4.1. Input Data Required**

The list of validation anomalies chosen by the site team is the input to this SOP.

### **4.2. Output Data**

The comparison of the recovered items and analysis predictions will be documented in a Validation Report to be submitted by the Project Geophysicist.

## **5. Quality Control**

QC consists of performing the inspections on the Validation Checklist that is included as Attachment 1 to this SOP. This checklist will be completed by the QC Geophysicist and will be observed by the Project geophysicist who will document the implementation of this SOP in the Geophysics Daily QC Report.

The measurement quality objectives (MQOs) for this SOP are presented in Worksheet #22 of the QAPP.

## **6. Reporting**

Achievement of the Recovered Object Verification MQOs (see the MQOs Worksheet #22) will be documented by the QC Geophysicist by completion of the QC Checklist in Attachment 1 to this SOP.



## SOP 10

### Attachment 1 Follow-on QC Checklist for Validation

This checklist is to be completed by the QC Geophysicist for a series of recovered items.

Series of anomalies covered by this verification: From \_\_\_\_\_ To \_\_\_\_\_

Date: \_\_\_\_\_ Time: \_\_\_\_\_

QC Step	QC Process	Yes/No	Initial of Data Processor
1. Qualifications	Is the same QC Geophysicist being used? If not, has the qualifications of the new person been verified?		
2. Recovered object comparison	Did the QC Geophysicist compare each recovered item to the analysis predictions i/a/w this SOP?		
3. Submission of Validation Report	Was the Validation Report submitted i/a/w this SOP?		

QC Geophysicist: \_\_\_\_\_ Date: \_\_\_\_\_

Project Geophysicist: \_\_\_\_\_ Date: \_\_\_\_\_